

ODSL 96B

Optical distance sensors

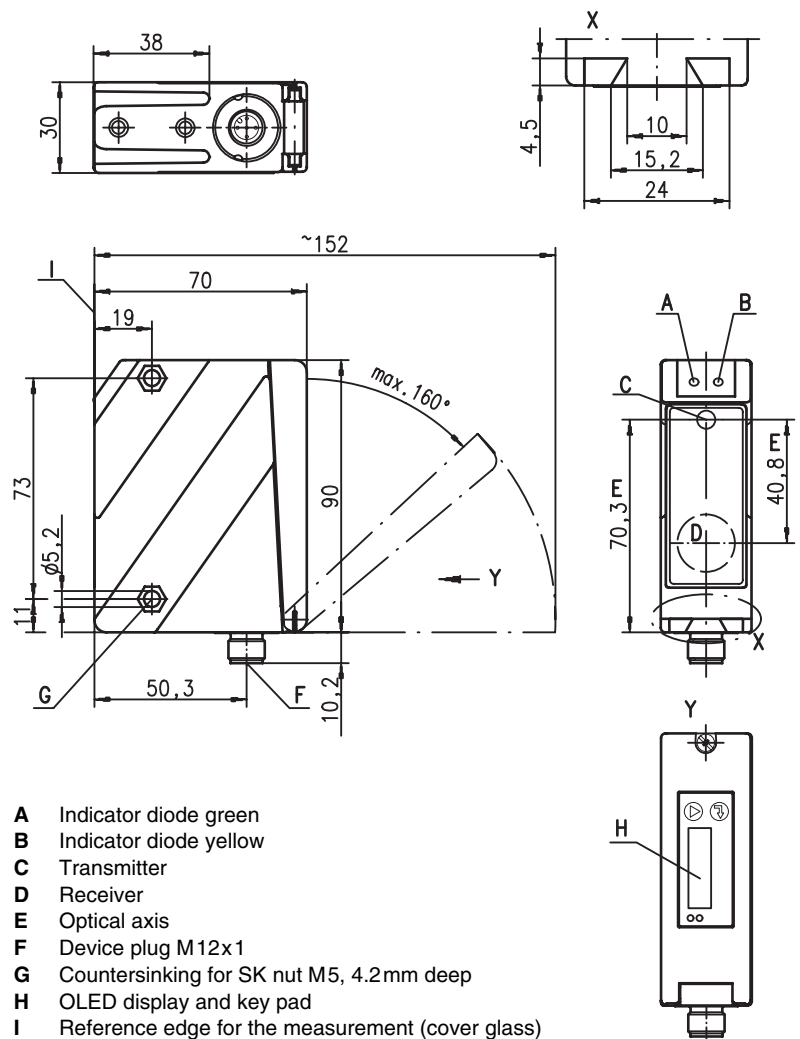

Dimensioned drawing



- A Indicator diode green
- B Indicator diode yellow
- C Transmitter
- D Receiver
- E Optical axis
- F Device plug M12x1
- G Countersinking for SK nut M5, 4.2mm deep
- H OLED display and key pad
- I Reference edge for the measurement (cover glass)

Electrical connection

ODSL 96B M/V6...-S12	
18-30V DC +	1 — br/BN
teach in	2 — ws/WH
GND	3 — bl/BU
○ ● ⊕	4 — sw/BK
1-10V	5 — gr/GY

ODSL 96B M/C6...-S12	
18-30V DC +	1 — br/BN
teach in	2 — ws/WH
GND	3 — bl/BU
○ ● ⊕	4 — sw/BK
4-20mA	5 — gr/GY

Art. Nr. 501 08379

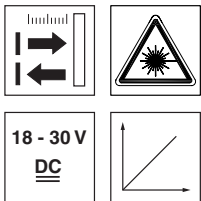

150 ... 1200mm

- Wide rectangular-shaped light spot for measurements on objects with openings
- Reflection-independent distance information
- Highly insensitive to extraneous light
- Analogue current or voltage output
- PC/OLED display and key pad for configuration
- Measurement value is indicated in mm on OLED display
- Measurement range and mode adjustable
- Teachable switching output and analogue output

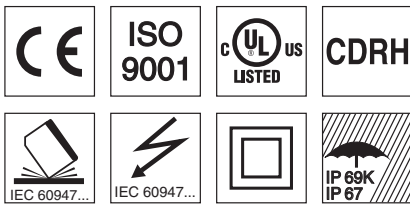

Accessories:

(available separately)

- Mounting systems
- Cable with M12 connector (K-D ...)
- Configuration software

We reserve the right to make changes • ods_44gb.fm

Specifications

Optical data

Measurement range ¹⁾	150 ... 1200mm
Resolution ²⁾	0.1 ... 1.5mm
Light source	laser
Wavelength	655nm (red light)
Light spot	divergent, approx. 15 x 4mm ² at 800mm

Error limits (relative to measurement distance)

Absolute measurement accuracy ¹⁾	± 1.5% up to 800mm, ± 2% up to 1200mm
Repeatability ³⁾	± 0.5% up to 800mm, ± 1% up to 1200mm
b/w detect. thresholds (6 ... 90% rem.)	≤ 1% up to 800mm, ≤ 1.5% up to 1200mm
Temperature compensation	yes ⁴⁾

Timing

Measurement time	1 ... 5 ¹⁾ ms
Response time ¹⁾	≤ 15ms
Delay before start-up	≤ 300ms

Electrical data

Operating voltage U _B ⁵⁾	18 ... 30VDC (incl. residual ripple)
Residual ripple	≤ 15% of U _B
Open-circuit current	≤ 150mA
Switching output	push-pull switching output ⁶⁾ , PNP light switching, NPN dark switching
Signal voltage high/low	≥ (U _B -2 V) / ≤ 2V
Analogue output	voltage 1 ... 10V, R _I ≥ 2kΩ current 4 ... 20mA, R _L ≤ 500Ω

Indicators

Green LED	continuous light flashing off
Yellow LED	continuous light flashing off

teach-in on GND

ready	
fault	teaching procedure
no voltage	
object inside teach-in measurement distance	teaching procedure
object outside teach-in measurement distance	

teach-in on +U_B

ready	
fault	teaching procedure
no voltage	
object inside teach-in measurement distance	teaching procedure
object outside teach-in measurement distance	

Mechanical data

Housing	diecast zinc
Optics cover	glass
Weight	380g
Connection type	M 12 connector

Metal housing

diecast zinc
glass
380g
M 12 connector

Environmental data

Ambient temp. (operation/storage)	-20°C ... +50°C / -30°C ... +70°C
Protective circuit ⁷⁾	1, 2, 3
VDE safety class ⁸⁾	II, all-insulated
Protection class	IP 67, IP 69K ⁹⁾
Laser class	2 (acc. to EN 60825-1)
Standards applied	IEC 60947-5-2

- 1) Luminosity coefficient 6% ... 90%, complete measurement range, at 20°C, medium range of U_B, measurement object ≥ 50x50mm²
- 2) Minimum and maximum value depend on measurement distance
- 3) Same object, identical environmental conditions, measurement object ≥ 50x50mm²
- 4) Typ. ± 0.02 %/K
- 5) For UL applications: for use in class 2 circuits according to NEC only
- 6) The push-pull switching outputs must not be connected in parallel
- 7) 1=transient protection, 2=polarity reversal protection, 3=short circuit protection for all outputs
- 8) Rating voltage 250VAC, with cover closed
- 9) IP 69K test acc. to DIN 40050 part 9 simulated, high pressure cleaning conditions without the use of additives. Acids and bases are not part of the test.

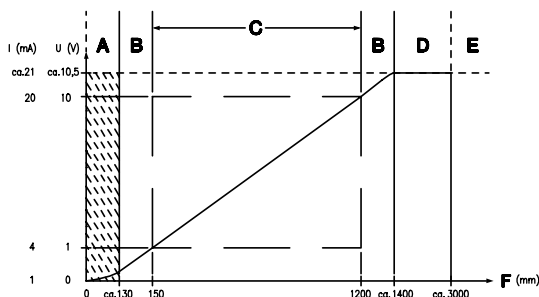

- A Area not defined
- B Linearity not defined
- C Measurement range
- D Object present
- E No object detected
- F Measurement distance

Order guide

With M12 connector

	Designation	Part No.
Current output	ODSL 96B M/C6.XL-1200-S12	501 06736
Voltage output	ODSL 96B M/V6.XL-1200-S12	501 06737

Tables

Diagrams

Remarks

- Measurement time depends on the reflectivity of the measurement object and on the measurement mode.
- **Approved purpose:** The ODSL 96B distance sensors are optical electronic sensors for the optical, contactless measurement of distance to objects.

LASER LIGHT DO NOT STARE INTO BEAM	
Maximum Output:	1.2mW
Pulse duration:	22ms
Wavelength:	655nm
CLASS 2 LASER PRODUCT EN60825-1:2003-10	

LASER LIGHT DO NOT STARE INTO BEAM	
Maximum Output:	1.2mW
Pulse duration:	22ms
Wavelength:	655nm
CLASS 2 LASER PRODUCT IEC 60825-1:1993+A2:2001 Complies with 21 CFR 1040.10	