

ODSL 8

Optical laser distance sensors

en 06-2010/01 50103923



Dimensioned drawing

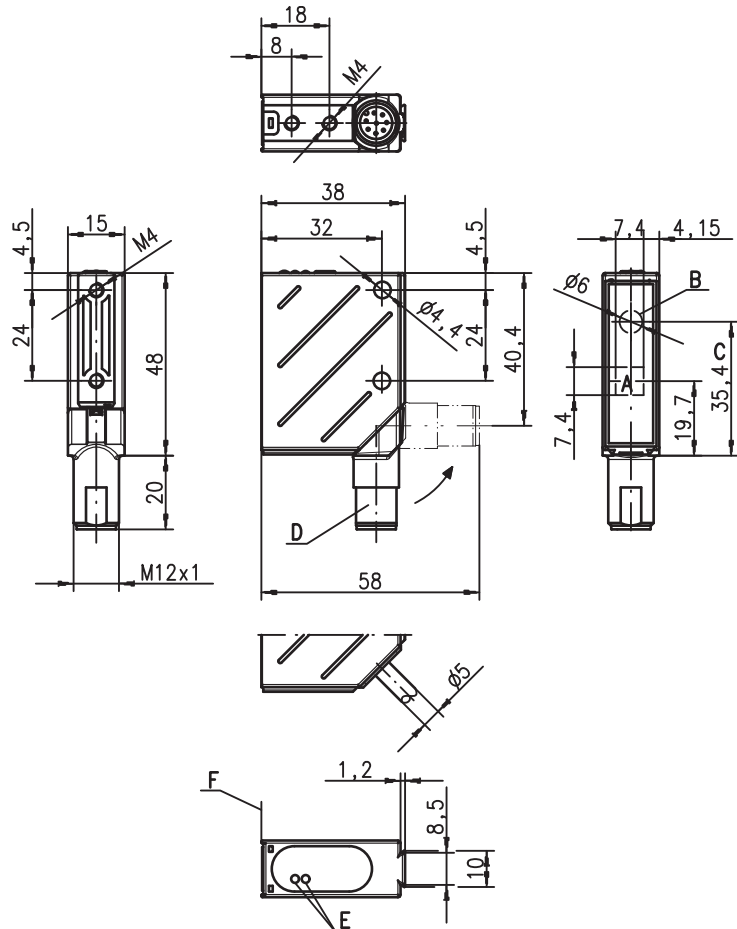

- A Receiver
- B Transmitter
- C Optical axis
- D 90° turning connector
- E LED yellow, green
- F Operational control (rotary switch)
- G Reference edge for the measurement (cover glass)

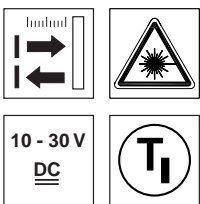

20 ... 500mm

- Reflection-independent distance information
- Highly insensitive to extraneous light
- 2 teachable switching outputs (push-pull)
- M12 turning connector
- Easy alignment through visible red light

Electrical connection

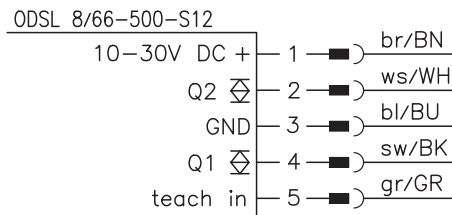

Accessories:

(available separately)

- Mounting systems
- Cable with M12 connector (K-D ...)
- Control guard

We reserve the right to make changes • ods_31en.fm

Specifications

Optical data

Measurement range ¹⁾	20 ... 500mm
Resolution ²⁾	0.1 ... 0.5mm
Hysteresis ²⁾	0.6 ... 32mm
Light source	laser
Wavelength	630nm (visible red light)
Light spot	2x6mm ² at 500mm
Laser warning notice	see remarks

Error limits (relative to measurement distance)

Absolute measurement accuracy ¹⁾	± 2% up to 200mm / ± 4% 200 ... 500mm
Repeatability ³⁾	± 1% up to 200mm / ± 3% 200 ... 500mm
b/w detection thresh. (6 ... 90% rem.)	≤ 1.5%
Temperature drift	≤ 0.2%/°C

Timing

Measurement time	2 ... 7ms
Response time	≤ 20ms
Delay before start-up	≤ 300ms

Electrical data

Operating voltage U _B	10 ... 30VDC (incl. residual ripple)
Residual ripple	≤ 15% of U _B
Open-circuit current	≤ 50mA
Switching output/function ⁴⁾	2 push-pull switching outputs pin 2: Q2, PNP light switching, NPN dark switching pin 4: Q1, PNP light switching, NPN dark switching
Signal voltage high/low	≥ (U _B -2 V)/≤ 2V

Indicators

Green LED	continuous light	ready
	flashing (no Teach)	fault, teach values were not applied
	off	no voltage
Yellow LED	continuous light	object within teach-in measurement distance (output Q1 ⁵⁾)
	flashing (no Teach)	teach values were not applied
	off	object outside teach-in measurement distance (output Q1 ⁴⁾)

Mechanical data

Housing	metal
Optics cover	glass
Weight	70g
Connection type	M12 connector, 5-pin, turning

Environmental data

Ambient temp. (operation/storage)	-40°C ... +50°C/-40°C ... +70°C
Protective circuit ⁶⁾	2, 3
VDE safety class ⁷⁾	II, all-insulated
Protection class ⁸⁾	IP 67, IP 69K ⁹⁾
Laser class	2 (acc. to EN 60825-1)
Standards applied	IEC 60947-5-2

- 1) Luminosity coefficient 6% ... 90%, at 20°C, measurement object ≥ 50x50mm²
- 2) Minimum and maximum value depend on measurement distance
- 3) Same object, identical environmental conditions, measurement object ≥ 50x50mm²
- 4) The push-pull switching outputs must not be connected in parallel
- 5) No display for output Q2
- 6) 2=polarity reversal protection, 3=short-circuit protection for all outputs
- 7) Rating voltage 250VAC
- 8) In stop position of the turning connector (turning connector locked)
- 9) IP 69K test acc. to DIN 40050 part 9 simulated, high pressure cleaning conditions without the use of additives, acids and bases are not part of the test

Characteristic curve of switching outputs:

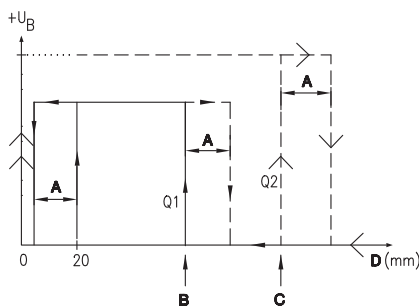

- A Hysteresis
- B Switching point Q1 (teach point)
- C Switching point Q2 (teach point)
- D Measurement distance

Order guide

	Designation	Part No.
With M12 connector	ODSL 8/66-500-S12	501 01880

Tables

Diagrams

Remarks

- Measurement time depends on the reflectivity of the measurement object and on the measurement mode.
- **Approved purpose:**
The ODSL 8 laser distance sensors are optical electronic sensors for the optical, contactless measurement of distance to objects.

LASER LIGHT DO NOT STARE INTO BEAM	
Maximum Output:	1.2mW
Pulse duration:	3ms
Wavelength:	635nm
CLASS 2 LASER PRODUCT EN60825-1:2003-10	

ODSL 8

Optical laser distance sensors

T₁ teach-in with rotary switch

1. Position measurement object at the desired distance (①).

2. Turn rotary switch into the desired position (Low, High, 1, 2) (②).
Wait for optical confirmation by flashing of the LEDs.

Teach function	Rotary switch position	Green LED	Yellow LED
switching output Q1	1	flash synchronously	
switching output Q2	2	flash alternatingly	

3. For teaching, position rotary switch onto "Run" (③).
Wait for optical confirmation by end of flashing signal (green LED on).

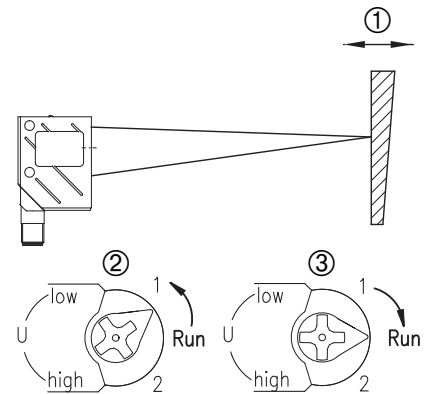

T₁ teach-in via input

1. Position measurement object at the desired distance.
2. The respective teach function is activated by applying +U_B to teach input (pin 5). The teach event is signalled by flashing of the LEDs.

Teach function	Duration of the teach signal	Green LED	Yellow LED
switching output Q1	2 ... 4s	flash synchronously	
switching output Q2	4 ... 6s	flash alternatingly	

3. To finish the teach event, disconnect the teach input from +U_B or switch it to 0V after the desired time.
4. A successful teach event is signalled by the end of the flashing (green LED on)

Error messages

Continuously flashing LEDs signal an unsuccessful teach event (sensor not ready):

Green LED	Yellow LED	Error
flash synchronously		teach switching output Q1 unsuccessful
flash alternatingly		teach switching output Q1 unsuccessful

Remedy:

- Repeat teach event or
- Disconnect sensor from voltage to restore the old values.

Typical areas of application of optical distance sensors

Continuous distance measurement



Positioning tasks

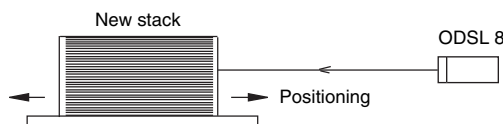

Filling level control

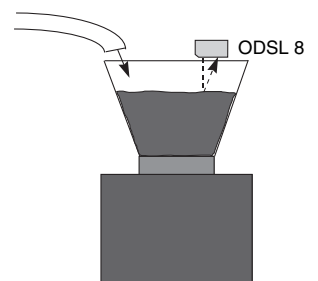

Installation instructions

Mounting systems are available which have to be ordered separately at Leuze electronic. Apart from this, the drilled-through holes and threaded holes are suitable for the individual mounting of the ODSL 8, depending on the area in which it is used. When mounting, avoid application of excessive force on the housing.

Preferred movement of the objects

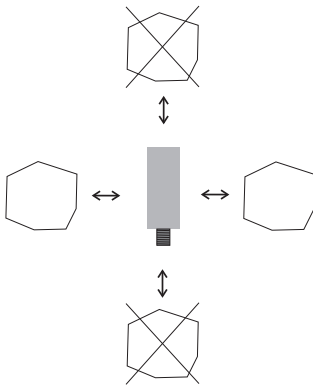

Preferred mounting in connection to objects with structured surface

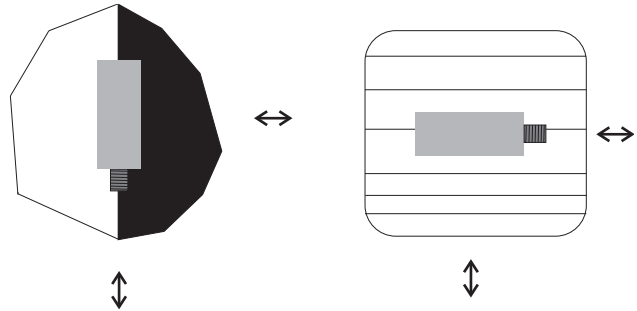

View through a chase

If the ODSL 8 has to be installed behind a cover, the chase has to have at least the size of the optical glass cover. Otherwise, a correct measurement is not possible or can not be guaranteed.

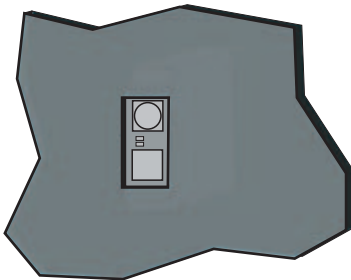

Alignment to measurement objects with reflecting surfaces

If the measurement object to be detected has a reflecting surface, a measurement may not be possible depending on the angle in which the light is reflected by the measurement object's surface. Adjust the angle between the sensor and the measurement object such that the sensor can reliably detect the measurement object.

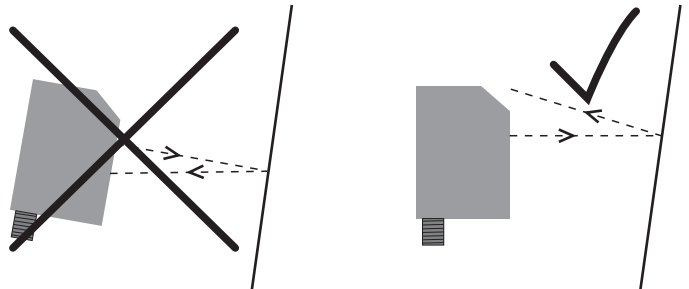

Working Safely



Attention Laser Radiation!

The optical distance sensors ODSL 8 operate with a red light laser of class 2 acc. to EN 60825-1. If you look into the beam path over a longer time period, the retina of your eye may be damaged!

Never look directly into the beam path! Do not point the laser beam of the ODSL 8 at persons!

When mounting and aligning the ODSL 8 take care to avoid reflections of the laser beam off reflective surfaces!

The use of operating and adjusting devices other than those specified in the technical description, carrying out of differing procedures, or improper use of the optical laser distance sensor may lead to dangerous exposure to radiation!

The use of optical instruments or devices in combination with the device increases the danger of eye damage!

Adhere to the applicable legal and local regulations regarding protection from laser beams acc. to EN 60825-1 in its latest version.

The ODSL 8 uses a laser diode with low power in the visible red light range with an emitted wavelength of about 630nm.

The glass optics cover is the only opening through which the laser radiation can escape from the device. The housing of the ODSL 8 is sealed and has no parts that need to be adjusted or maintained by the user. The device must not be tampered with and must not be changed in any way! The destruction of the seal voids the warranty!

Notice!



It is important that you attach the sticky labels supplied to the device (notice signs and laser emission symbol)! If the signs would be covered due to the installation situation of the ODSL 8, attach them close to the ODSL 8 such that reading the notices cannot lead to looking into the laser beam!