

**ODS 96 Ex**

**Optical laser distance sensors**

Part No. 501 09362



**Dimensioned drawing**

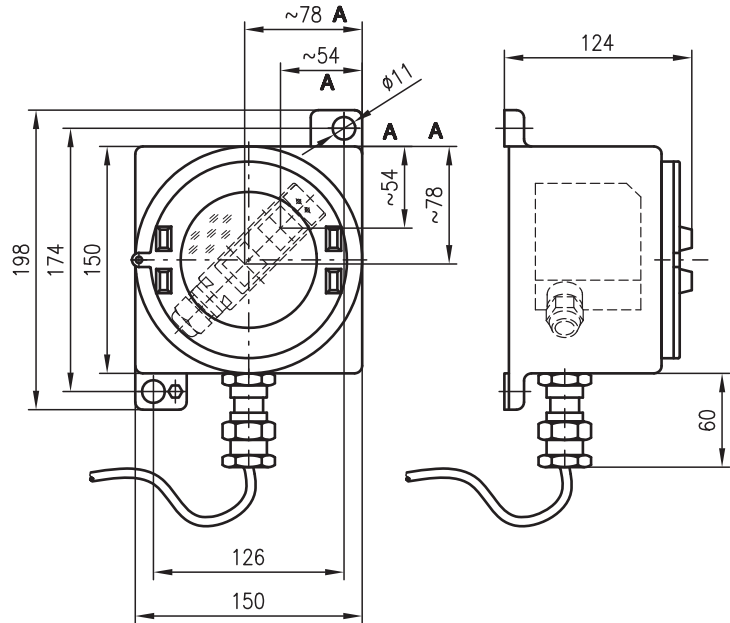

A Optical axis

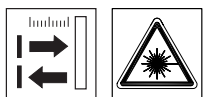

**250 ... 5000mm**

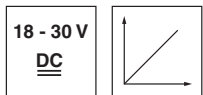

- Reflection-independent distance information
- Highly insensitive to extraneous light
- Analogue current output
- Measurement range and mode adjustable
- Teachable switching output
- 2 PNP switching outputs
- Easy alignment through visible red light
- EC type examination certificate CESI 02 ATEX 096
- Ex II 2G EEx d IIC T6
- Ex II 2D IP 66 T 85°C

**Electrical connection**

420	br/BN
18-30V DC +	ws/WH
teach in	bl/BU
GND	sw/BK
4-20mA	gr/GR

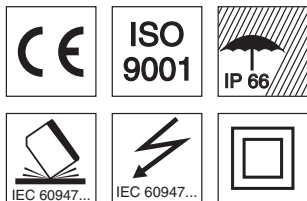

**Accessories:**

(available separately)

- Configuration software

We reserve the right to make changes • ods\_ex\_18gb.fm

## Specifications

### Optical data

Measurement range <sup>1)</sup>	250 ... 5000mm
Resolution <sup>2)</sup>	1 ... 20mm
Light source	laser (modulated light)
Wavelength	660nm (visible red light)
Light spot diameter	divergent, 3x8mm <sup>2</sup> at 1200mm (laser)
Laser warning notice	see remarks

### Error limits

Absolute measurement accuracy <sup>1)</sup>	± 2.5% up to 3m/± 5% at 3 ... 5m
Repeatability <sup>3)</sup>	± 2% up to 3m/± 3% at 3 ... 5m
b/w detect. thresholds (6 ... 90% rem.)	≤ 2% up to 3m/≤ 3% at 3 ... 5m

### Timing

Switching frequency	10 ... 100Hz
Response time	≤ 100ms
Delay before start-up	≤ 300ms

### Electrical data

Operating voltage U <sub>B</sub>	18 ... 30VDC (incl. residual ripple)
Residual ripple	≤ 15% of U <sub>B</sub>
Open-circuit current	≤ 150mA
Switching output	PNP transistor, high-active
Signal voltage high/low	≥ (U <sub>B</sub> -2V)/≤ 2V
Analogue output	voltage 1 ... 10V, R <sub>i</sub> ≥ 2kΩ current 4 ... 20mA, R <sub>L</sub> ≤ 500Ω

### Indicators

LED green	continuous light	<b>teach-in on GND</b>	<b>teach-in on +U<sub>B</sub></b>	
	flashing			ready
	off			fault
LED yellow	continuous light		teaching procedure	
	flashing	no voltage		
	off	object inside teach-in measurement distance	teaching procedure	
		object outside teach-in measurement distance		

### Mechanical data

Housing	diecast zinc
Optics cover	glass
Weight	3300g
Connection type	cable, 5m long

### Environmental data

Ambient temp. (operation/storage)	-20°C ... +40°C/-30°C ... +70°C
Protective circuit <sup>4)</sup>	1, 2, 3
VDE safety class <sup>5)</sup>	II
Protection class	IP 66
Standards applied	IEC 60947-5-2

### Explosion protection

Labelling (CENELEC) ⊕ Ex II 2G EEx d IIC T6 ⊕ Ex II 2D IP 66 T85°C

- 1) Luminosity coefficient from 6% ... 90%, over complete temperature range, measured object ≥ 50x50mm<sup>2</sup>
- 2) Minimum and maximum value depend on measurement distance and configuration of the analogue output
- 3) Same object, identical environmental conditions, temperature range -20°C ... +40°C
- 4) 1=transient protection, 2=polarity reversal protection, 3=short circuit protection for all outputs
- 5) Rating voltage 250VAC

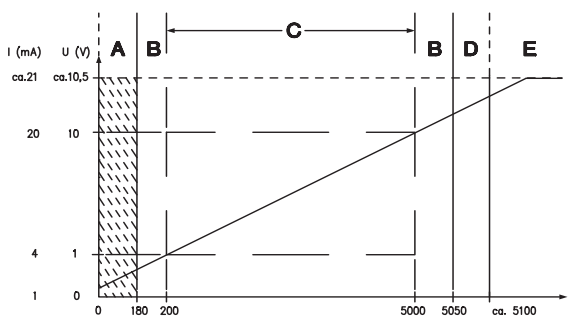

- A Area not defined
- B Linearity not defined
- C Measurement range
- D Object present
- E No object detected
- F Measurement distance

## Tables

## Diagrams

## Remarks

- To configure with the 'ODS 96' PC software, the sensor must be removed from the Ex housing.
- Switching frequency depends on the reflectivity of the measurement object and on the measurement mode.
- **Teaching procedure:** Position measured object at desired measurement distance. Connect teach input to +U<sub>B</sub> for ≥ 2s. Reconnect teach input to GND, switching output is programmed.
- **Approved purpose:** The ODS 96M distance sensors are optical electronic sensors for the optical, contactless measurement of distance to objects.

LASERSTRAHLUNG / LASER LIGHT  
 NICHT IN DEN STRAHL BLICKEN  
 DO NOT STARE INTO BEAM  
 LASERKLASSE 2  
 CLASS 2 LASER PRODUCT  
 IEC 60825-1-am2 (2001-01)

**ODS 96**  
 Pulse duration < 32ms  
 Quiescent period ≥ 5ms  
 P<sub>max</sub> ≤ 1mW  
 λ = 670nm

## Order guide

### Cable connection

Current output	<b>Designation</b>	<b>Part No.</b>
	ODS 96M/V-5510-420 Ex d	500 41126

## Operating Instructions for ODS(L) 96(B) Ex d for Use in Potentially Explosive Areas

### Intended application range

The sensors produced by Leuze electronic GmbH + Co. KG for use in potentially explosive areas operate according to the optoelectronics principle. Without making physical contact, these sensors detect objects located within or passing through the light beam, and measure the distance to these objects.

The distance sensors of type ODS(L) 96(B) Ex d have a housing of encapsulated pressure-proof design according to EN 50014: 1997+A1...A2, EN 50018: 2000 and EN50281-1-1: 1999. This technology enables operation in zones 1 and 21 and zones 2 and 22.

### Installation, Commissioning



#### Attention!

Electrical equipment may endanger humans and (where applicable) animal health, and may threaten the safety of goods if used incorrectly and under unfavourable conditions in potentially explosive areas.

A safe operation in potentially explosive areas is only possible if the equipment is used properly and for its intended purpose.

The distance sensors of type ODS(L) 96(B) Ex d must only be installed and maintained by trained electricians.

When installing the sensors in Ex zones 1 and 21, the connection cable must be connected in a connection space with increased safety Ex e, or outside the Ex area.

The housing must be connected to the protective conductor system at the marked external connection terminal. For this purpose, always use a cable lug and make the connection as shown in the diagram. Fastening screw (A) is to be secured with a lock washer (B) to protect against loosening.

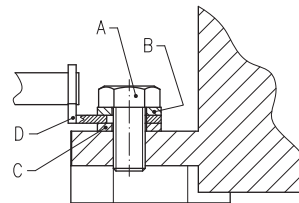

- A** Screw M6
- B** Lock washer
- C** Washer
- D** Cable lug

The respective applicable national regulations for the installation of electrical equipment in potentially explosive areas must be observed.

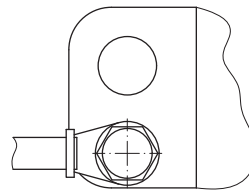

### Maintenance

No changes may be made to the devices of type ODS(L) 96(B) Ex d for potentially explosive areas.

Repairs to the sensors may only be performed by persons trained for such work or by the manufacturer. Defective devices must be replaced immediately.

The housing must not be opened while the power is on! After switching off power, wait at least 10min. before opening the housing.

Cyclical maintenance of the sensors is not necessary.

Depending on the environmental conditions, it may occasionally be necessary to clean the light-emission surfaces of the sensors. This cleaning must only be performed by persons trained for performing this task. A soft, damp cloth should be used for this purpose. Cleaning agents that contain solvents must not be used.

### Chemical resistance

The sensors of type ODS(L) 96(B) Ex d demonstrate good resistance against many diluted acids and bases.

Exposure to organic solvents is possible only under certain circumstances and only for short periods of time.

Resistance to chemicals should be examined on a case by case basis.

**BARTEC**

Erklärung der EG Konformität  
CE Declaration of Conformity  
Attestation de Conformité CE

BARTEC NEDERLAND b.v.  
Boelewerf 25  
NL 2987 VD RIDDERKERK

  
**0344**

Wir/We/Nous

**BARTEC NEDERLAND b.v.**

Erklären in alleiniger Verantwortung/declare under our sole responsibility/  
attestons sous notre seule responsabilité  
daß das Produkt/that the product/que le produit

**Druckfest gekapseltes Gehäuse Typ GUB-0V, komplett mit  
optische Laser-Distanzsensor, LEUZE Typ ODS 96**

**Zündschutzart:  II 2GD EEx d IIC T6 IP 66 T85°C**

auf das sich diese Erklärung bezieht/to which this declaration relates/se  
référant à cette attestation

den Bestimmungen der folgenden Richtlinien entspricht/is in accordance  
with the provision of the following directives/correspond aux dispositions  
des directives suivantes

**ATEX Directive 94/9/EC – 1994**

und mit folgenden Normen oder normativen Dokumenten übereinstimmt/  
and is in conformity with the following standards or other normative  
documents/ et est conforme aux normes ou documents normatifs  
cidessous

**EN 50014 : 1997+A1...A2**

**EN 50018 : 2000**

**EN 50281-1-1 : 1999**

Weitere angewendete Normen/ further used standards/ norme plus utiliser

**EN 60079-0: 2006, EN 60079-1: 2004, EN 61241-0: 2006, EN 61241-1: 2004**

Ridderkerk, October 9, 2008

**BARTEC**  
NEDERLAND b.v.



Postbus 4173  
2980 GD Ridderkerk  
Tel.: (0180) 41 05 88

Boelewerf 25  
2987 VD Ridderkerk  
Fax: (0180) 41 41 34

Dipl. Ing. K. Neleman  
ATEX authorised

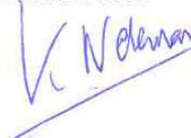

Erklärung der EG Konformität GUB-0V LEUZE ODS 96