

PRK 96 Ex n

Retro-reflective photoelectric sensors with polarisation filter

Part No. 501 10834

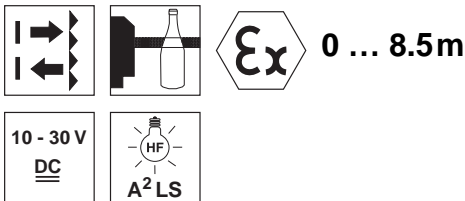

- Retro-reflective photoelectric sensor for detection of transparent media
- Robust metal housing with glass cover, protection class IP 67/IP 69K for industrial application
- Sensitivity adjustment
- The autocollimation principle used ensures that the device functions reliably over the entire range (0 ... max.)
- High switching frequency for detection of fast events
- Connection via M12 connector or terminal compartment
- Ex II 3G Ex nA II T4
- Ex II 3D Ex tD A22 IP67 T70°C



Accessories:

(available separately)

- Mounting systems (BT 96, UMS 96, BT 450.1-96)
- M12 connectors (KD ...)
- Ready-made cables (K-D ...)
- Reflectors
- Reflective tapes
- Alignment aid ARH 96
- Interlocking guard K-VM12-Ex (Part No. 501 09217)

Dimensioned drawing

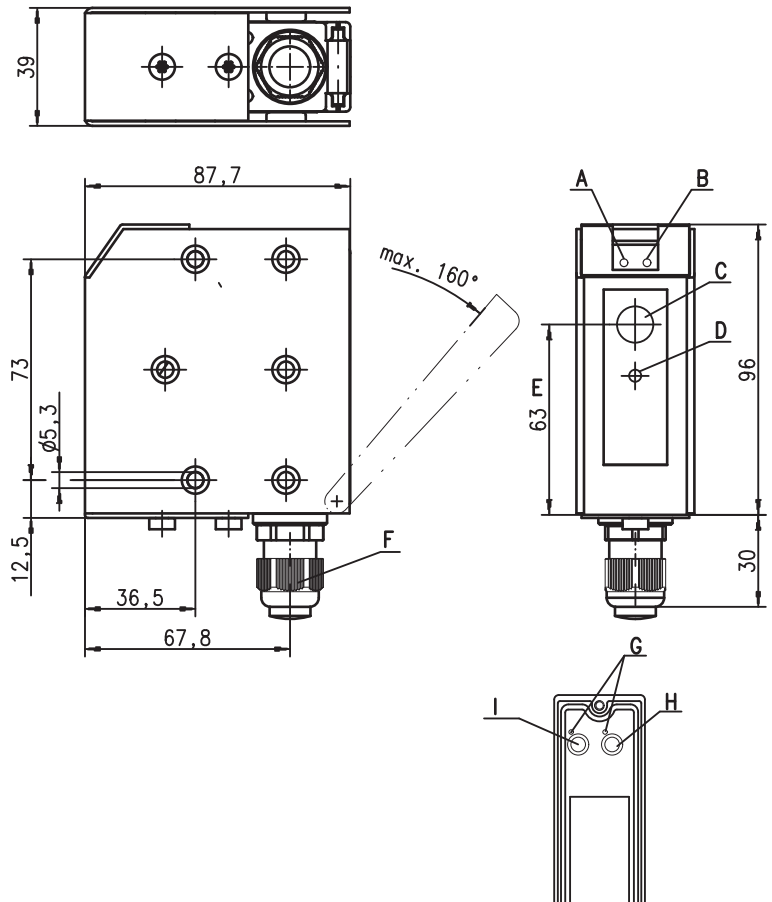

- A Green indicator diode
- B Yellow indicator diode
- C Receiver
- D Transmitter
- E Optical axis
- F Screwed cable gland M16x1,5 for Ø 5 - 10mm
- G Yellow indicator diode
- H Scanning range adjustment Q₂
- I Scanning range adjustment Q₁

Electrical connection

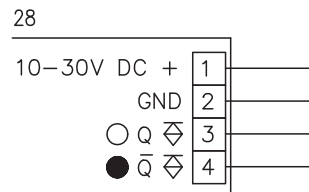

We reserve the right to make changes • 96_ Ex_ b19gb_fm

Specifications

Optical data

Typ. op. range limit (TK(S) 100x100) ¹⁾	0 ... 8.5m
Operating range ²⁾	see tables
Light source	LED (modulated light)
Wavelength	660nm (visible red light/polarised)

Timing

Switching frequency	1000Hz
Response time	0.5ms
Delay before start-up	≤ 200ms

Electrical data

Operating voltage U_B	10 ... 30VDC (incl. residual ripple)
Residual ripple	≤ 15% of U_B
Open-circuit current	≤ 30mA
Switching output	2 PNP transistor outputs, complementary
Function characteristics	light/dark switching
Signal voltage high/low	≥ ($U_B - 2V$) / ≤ 2V
Output current	max. 100mA
Sensitivity	adjustable with potentiometer

Indicators

Yellow LED	light path free
LED yellow flashing	light path free, no performance reserve

Mechanical data

Housing	diecast zinc
Optics cover	glass
Weight	380g
Connection type	terminals or M12 connector

Environmental data

Ambient temp. (operation/storage)	-20°C ... +50°C / -40°C ... +55°C
Protective circuit ³⁾	1, 2, 3, 4
VDE safety class ⁴⁾	II, all-insulated
Protection class	IP 67, IP 69K ⁵⁾
LED class	1 (acc. to EN 60825-1)
Standards applied	IEC 60947-5-2

Explosion protection

Labelling (CENELEC)	II 3G Ex nA II T4	II 3D Ex tD A22 IP67 T70°C
---------------------	-------------------	----------------------------

- 1) Typ. operating range limit: max. attainable range without performance reserve
- 2) Operating range: recommended range with performance reserve
- 3) 1=transient protection, 2=polarity reversal protection, 3=short circuit protection for all outputs, 4=interference blanking
- 4) Rating voltage 250 VAC
- 5) IP 69K test acc. to DIN 40050 part 9 simulated, high pressure cleaning conditions without the use of additives, acids and bases are not part of the test

Tables

Reflectors	Operating range
1 TK(S) 100x100	0 ... 7m
2 MTK(S) 50x50	0 ... 6m
3 TK(S) 30x50	0 ... 4m
4 TK(S) 20x40	0 ... 3.5m
5 TK(S) 82	0 ... 5m
6 Tape 2 100x100	0 ... 3m

1	0.1			7	8.5
2	0.1			6	7.5
3	0.1		4		5
4	0.1	3.5		4	
5	0.1			5	6
6	0.1	3		3.5	

- Operating range [m]
- Typ. operating range limit [m]

TK ... = adhesive
 TKS ... = screw type
 Tape 2 = adhesive

Diagrams

Typ. response behaviour (TKS 100x100)

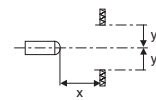
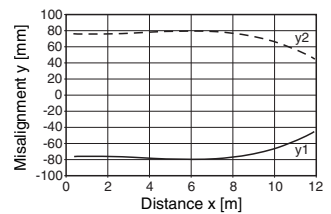

Order guide

	Designation	Part No.
With terminals	PRK 96M/P-2838-28 Ex n	501 09523

Remarks

Ex devices

Operating instructions for sensors for use in potentially explosive areas of Group II, Category 3, Zones 2 ("Gas Ex") and 22 ("Dust Ex")

The sensors produced by Leuze electronic GmbH + Co. KG for use in potentially explosive areas are sensors which function on the optical electronic principle. Without making physical contact, these sensors detect objects which are located in or which pass through the light beam.



Attention!

Electrical equipment may endanger humans and (where applicable) animal health, and may threaten the safety of goods if used incorrectly and under unfavourable conditions in potentially explosive areas.

A safe operation in potentially explosive areas is only possible if the equipment is used properly and for its intended purpose.

This requires that the installation and operating instructions are adhered to and that appropriate measures are taken to ensure that this is effectively and permanently ensured.



Notes!

- In order to achieve a safe operation of sensors of Group II, Category 3, in potentially explosive areas, installation and protective devices appropriate to the application must ensure that operational events do not damage or overload the equipment.

Installation, Commissioning

In order to comply with the requirements acc. to EN 61 241-1 and EN 60 079-15, the following prerequisites must be met:

- Devices with connector (e.g. Series 46B) must be equipped with an additional safeguard or a mechanical interlocking guard K-VM12-Ex (Part No. 501 09217) to avoid unintended separation of the connectors. The warning sign "Do not disconnect under voltage" that is supplied with the device must be attached to the sensor or its mounting bracket so that it is clearly visible.
- Devices with terminal compartment lid (e.g. Series 96) must only be commissioned if the terminal compartment lid of the device is properly sealed.
- Connection cables and connectors must be protected from excessive or unintended pulling or pushing strain.
- The requirements according to EN 61 241-1 regarding dust deposits and temperatures must be observed.



Attention!

- Due to the physical circumstances, the sensors must not be used for the protection of persons or for purposes of emergency shutdown.
- The sensors must only be installed and maintained by trained electricians.
- The applicable regulations for the installation of electrical equipment in potentially explosive areas must be observed.

Maintenance

No changes may be made to the sensors for potentially explosive areas.

Repairs to the sensors may only be performed by persons trained for such work or by the manufacturer. Defective devices must be replaced immediately.

Cyclical maintenance of the sensors is not necessary.

Depending on the environmental conditions, it may occasionally be necessary to clean the optical surface of the sensors. This cleaning must only be performed by appropriately trained persons. We recommend using a soft, damp cloth for this purpose. Cleaning agents that contain solvents must not be used!

Chemical resistance

The sensors demonstrate good resistance against many diluted acids and bases.

Exposure to organic solvents is possible only under certain circumstances and only for short periods of time.

Resistance to chemicals should be examined on a case by case basis.

the **sensor** people

EG-Konformitätserklärung
-EC Declaration of Conformity
-Déclaration CE de conformité
-Declaración de conformidad CE

Name des Herstellers:

*-Name of the manufacturer:***Leuze electronic GmbH+Co. KG***-Le constructeur:**-Nombre del fabricante:*

Anschritt:

*-Address:***In der Braike 1 D-73277 Owen/ Teck***-domicilé:**-Dirección:*

Erklärt unter alleiniger Verantwortung, dass das Produkt mit der Bezeichnung:

*-declares under sole responsibility that the products with the designation:**-assumant sa pleine et entière responsabilité déclare que les produits avec la Référence:**-declara bajo su propia responsabilidad, que los productos con el Número de pedido:***PRK 96M/P-2838-28 Ex n****50109523****PRK 96M/P-3369-21 Ex n****50111088**

Kennzeichnung Gas:

*-Marking for gas:**-Certification gaz:**-Certificación gas:* **II 3G Ex nA II T4**

Kennzeichnung Staub:

*-Marking for dust:**-Certification poussière:**-Certificación polvo:* **II 3D Ex tD A22 IP67 T70°C**

Folgenden Richtlinien und Normen für die Gerätegruppe II, Gerätekategorie 3 entsprechen und bei bestimmungsgemäßer Verwendung und Beachtung der Betriebsanleitung die grundlegenden Sicherheits- und Gesundheitsanforderungen erfüllen.

*-conform to the following directives and standards for equipment group II, equipment category 3. They fulfill the basic health and safety requirements if used as intended and in accordance with the operating manual.**-sont conformes aux directives et normes ci-dessous pour les appareils du groupe II, catégorie 3 et que sous réserve d'utilisation conforme et du respect des consignes du manuel d'utilisation ceux-ci répondent aux exigences fondamentales pour la sécurité et la santé.**-corresponden a las directivas y normas para grupo de aparatos II categoría de aparatos 3 y que cumplen los requerimientos de seguridad y de salud al ser empleados debidamente teniendo en cuenta las instrucciones de uso.*

Richtlinie 94/9/EG / Richtlinie 89/336/EWG

*-Directive 94/9/EC / Directive 89/336/EEC**-Directive 94/9/CE / Directive 89/336/CEE**-Directiva 94/9/CE / Directiva 89/336/CEE***EN 60947-5-2:1998+A1:1999+A2:2004****EN 60825-1:1994+A1:2002+A2:2001****EN 60079-15:2005****EN 61241-1:2004**

Owen, den 11. Februar 2009

Dr. Harald Grübel (Geschäftsführer/ General Manager/ Directeur / Gerente)

Leuze electronic GmbH + Co. KG
In der Braike 1
D-73277 Owen
Telefon +49 (0) 7021 573-0
Telefax +49 (0) 7021 573-199
info@leuze.de
www.leuze.com

Leuze electronic GmbH + Co. KG, Sitz Owen, Registergericht Stuttgart, HRA 230712
Persönlich haftenden Gesellschafterin Leuze electronic Geschäftsführungs-GmbH,
Sitz Owen, Registergericht Stuttgart, HRB 230650
Geschäftsführer Dr. Harald Grübel (Vorsitzender), Karsten Just
USt-IdNr. DE145912521 | Zollnummer 2554202
Es gelten ausschließlich unsere aktuellen Verkaufs- und Lieferbedingungen.
Only our current Terms and Conditions of Sale and Delivery shall apply.