



LS 96 Ex n

Throughbeam photoelectric sensor



Dimensioned drawing

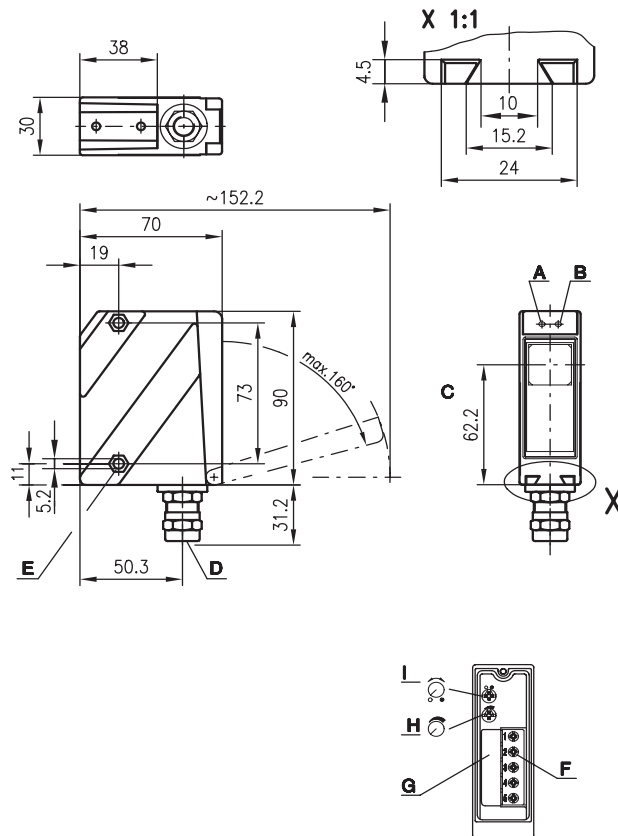

- A Indicator diode green
- B Indicator diode yellow
- C Optical axis
- D Screwed cable gland M16x1.5 for Ø 5 ... 9mm
- E Countersinking for SK nut M5, 4.2 deep
- F Connection terminals
- G Cable entry
- H Sensitivity adjustment
- I Light/dark switching



0 ... 150m



- Throughbeam photoelectric sensors with high performance reserve in infrared light
- Robust metal housing with shock-resistant optical window, protection class IP 67/ IP 69K for industrial application
- General light/dark switching and sensitivity adjustment for optimal adaptation to applications
- Connection via comfortable terminal compartment
- Ex II 3G EEx nA II T4
- Ex II 3D IP67 T60°C

Electrical connection

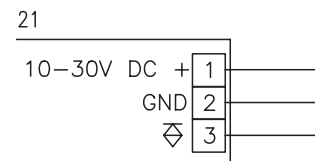
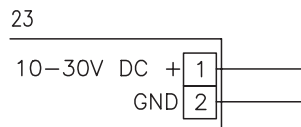

Accessories:

(available separately)

- Mounting systems (BT 96, BT 96.1, UMS 96, BT 450.1-96)
- Alignment aid ARH 96

We reserve the right to make changes • 96_ex_a15e.fm



Specifications

Optical data

Typ. operating range limit ¹⁾	0 ... 150m
Operating range ²⁾	0 ... 120m
Light source	LED (modulated light)
Wavelength	880nm

Timing

Sensor switching frequency	500Hz
Sensor response time	1 ms
Delay before start-up	≤ 200ms

Electrical data

Operating voltage U_B	10V ... 30V
Residual ripple	≤ 15% of U_B
Bias current	≤ 50mA
Switching output	PNP transistor
Function characteristics	light/dark switching (reversible)
Signal voltage high/low	≥ ($U_B - 2V$) / ≤ 2V (PNP)
Output current	max. 100 mA
Sensitivity	adjustable

Indicators

LED green	ready
LED yellow	light path free
LED yellow flashing	light path free, no performance reserve

Mechanical data

Housing	diecast zinc
Optics cover	polycarbonate
Weight	380g
Connection type	terminals, cable diameter 5 ... 9mm
Screwed cable gland	EEx e II clamping torque 3.5Nm

Environmental data

Ambient temp. (operation/storage)	-10°C ... +50°C / -40°C ... +70°C
Protective circuit ³⁾	1, 2
VDE safety class ⁴⁾	II, all-insulated
Protection class	IP 67, IP 69K ⁵⁾
LED class	1 (acc. to EN 60825-1)
Standards applied	IEC 60947-5-2

Explosion protection

Labelling (CENELEC)	⊕ Ex II 3G EEx nA II T4	⊕ Ex II 3D IP67 T60°C
---------------------	-------------------------	-----------------------

- 1) Typ. operating range limit: max. attainable range without performance reserve
- 2) Operating range: recommended range with performance reserve
- 3) 1=transient protection, 2=polarity reversal protection
- 4) Rating voltage 250VAC
- 5) IP 69K test acc. to DIN 40050 part 9 simulated, high pressure cleaning conditions without the use of additives, acids and bases are not part of the test

Tables

0	120	150
---	-----	-----

	Operating range [m]
	Typ. operating range limit [m]

Diagrams

Typ. response behaviour

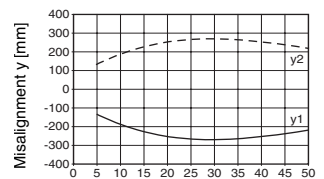

Distance x [m]

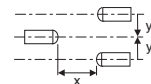

Order guide

	Designation	Part No.
Transmitter and receiver	LS 96M/P-3010-2 Ex n	
Transmitter	LSS 96 M-1070-23 Ex n	500 41191
Receiver	LSE 96 M/P-3010-21 Ex n	500 41192

Remarks

LS = Pair consisting of
 LSS = Transmitter
 LSE = Receiver

LS 96M/P-3010-2 Ex n
 LSS 96M-1070-23 Ex n
 LSE 96M/P-3010-21 Ex n



Operating instructions for sensors of type LS 96 M/P-3010-2 Ex for application in potentially explosive areas of zone 2 and 22.

The sensors produced by Leuze electronic GmbH + Co. KG for use in potentially explosive areas are sensors which function on the optical electronic principle. Without making physical contact, these sensors detect objects which are located in or which pass through the light beam.



Attention!

Electrical equipment may endanger humans and (where applicable) animal health, and may threaten the safety of goods if used incorrectly and under unfavourable conditions in potentially explosive areas.

A safe operation in potentially explosive areas is only possible if the equipment is used properly and for its intended purpose.

This requires that the installation and operating instructions are adhered to and that appropriate measures are taken to ensure that this is effectively and permanently ensured.



Notes!

- In order to achieve a safe operation of sensors of Group II, Category 3 in potentially explosive areas, installation and protective devices appropriate to the application must ensure that operational events do not damage or overload the equipment.
- The lid of the device's terminal compartment must only be opened if no potentially explosive atmosphere is present.

Installation, Commissioning

In order to comply with the requirements acc. to EN 50 021 and EN 50 281-1-1, the following prerequisites must be met:

- Due to the physical circumstances, the photoelectric sensors of series 96 must not be used for the protection of persons or for purposes of emergency shutdown.
- The photoelectric sensors of series 96 must only be installed and maintained by trained electricians.
- For the photoelectric sensors of the 96 series, screwed cable glands tested and certified according to EEx e are used for openly laid cables and lines. These screwed cable glands may only be replaced by comparable, approved screwed cable glands.
- The photoelectric sensors of the 96 series must only be commissioned if the terminal compartment lid of the device is properly sealed.
- The applicable regulations for the installation of electrical equipment in potentially explosive areas must be observed.
- The requirements according to EN 50281-1-2 regarding dust deposits and temperatures must be observed.

Maintenance

No changes may be made to the devices of type LS 96 M/P-3010-2 Ex n for potentially explosive areas.

Repairs to the sensors may only be performed by persons trained for such work or by the manufacturer. Defective devices must be replaced immediately.

Cyclical maintenance of the sensors is not necessary.

Depending on the environmental conditions, it may occasionally be necessary to clean the light-emission surfaces of the sensors.

This cleaning must only be performed by persons trained for performing this task.

A soft, damp cloth should be used for this purpose. Cleaning agents that contain solvents must not be used.

Chemical Resistance

The Series 96 sensors demonstrate good resistance against many diluted acids and bases.

Exposure to organic solvents is possible only under certain circumstances and only for short periods of time.

Resistance to chemicals should be examined on a case by case basis.



EG-Konformitätserklärung

EC Declaration of Conformity

Name des Herstellers:

Name of the manufacturer

Leuze electronic GmbH+Co KG

Anschrift:

Address:

In der Braike 1 D-73277 Owen/ Teck

erklärt unter alleiniger Verantwortung,
dass das Produkt:

declares under sole responsibility that the
products:

Bezeichnung:

Designation:

LSS 96M-1070-23 Ex n

Bestellnummer:

Order Number:

500 41191

Kennzeichnung Gas:

Marking for gas:

Ex II 3G EEx nA II T4

Kennzeichnung Staub:

Marking for dust:

Ex II 3D IP67 T60°C

folgenden Richtlinien und Normen für die
Gerätegruppe II, Gerätekategorie 3 entsprechen
und bei bestimmungsgemäßer Verwendung und
Beachtung der Betriebsanleitung die
grundlegenden Sicherheits- und
Gesundheitsanforderungen erfüllen.

conform to the following directives and standards
for equipment group II, equipment category 3.
They fulfill the basic health and safety
requirements if used as intended and in
accordance with the operating manual.

Richtlinie 94/9/EG

Directive 94/9/EC

Richtlinie 89/336/EWG

Directive 89/336/EEC

EN 60947-5-2 1998+A1: 1999
EN 60825-1: 1994+A1: 2002+A2: 2001
EN 50021: 1999
EN 50281-1-1: 1998+A1: 2002
DMT 02 ATEX ZQS/ E 166

Owen, den **17.10.04**

Michael Heyne
(Geschäftsführer/ General Manager)



Leuze electronic GmbH + Co KG
In der Braike 1
D-73277 Owen-Teck
Telefon (0 70 21) 57 30
Telefax (0 70 21) 57 31 99
http://www.leuze.de
info@leuze.de

Die Gesellschaft ist eine Kommanditgesellschaft
mit Sitz in Owen, Registergericht Kirchheim-Teck, HRA 712
Persönlich haftende Gesellschafterin ist die
Leuze-electronic Geschäftsführungs-GmbH mit Sitz in Owen
Registergericht Kirchheim-Teck, HRB 550
Geschäftsführer: Michael Heyne (Sprecher), Dr. Harald Grübel
Vorsitzender des Verwaltungsrats: Meinert Hahnemann

Deutsche Bank AG Stuttgart
Volksbank Kirchheim-Nürtingen
Kreissparkasse Esslingen-Nürtingen
Post giro Stuttgart

13 33 624
310 800 005
10 399 220
0 014 890 702

(BLZ 600 700 70)
(BLZ 612 901 20)
(BLZ 611 500 20)
(BLZ 600 100 70)

Steuer-Nr. 69026 / 10630
USt.-IdNr. DE 145912521

**EG-Konformitätserklärung****EC Declaration of Conformity**

Name des Herstellers:

*Name of the manufacturer***Leuze electronic GmbH+Co KG**

Anschrift:

*Address:***In der Braike 1 D-73277 Owen/ Teck**erklärt unter alleiniger Verantwortung,
dass das Produkt:*declares under sole responsibility that the
products:*

Bezeichnung:

*Designation:***LSE 96 M/P-3010-21 Ex n**

Bestellnummer:

*Order Number:***500 41192**

Kennzeichnung Gas

Marking for gas: **II 3G EEx nA II T4**

Kennzeichnung Staub:

Marking for dust: **II 3D IP67 T60°C**folgenden Richtlinien und Normen für die
Gerätegruppe II, Gerätekategorie 3 entsprechen
und bei bestimmungsgemäßer Verwendung und
Beachtung der Betriebsanleitung die
grundlegenden Sicherheits- und
Gesundheitsanforderungen erfüllen.conform to the following directives and standards
for equipment group II, equipment category 3.
They fulfill the basic health and safety
requirements if used as intended and in
accordance with the operating manual.

Richtlinie 94/9/EG

Directive 94/9/EC

Richtlinie 89/336/EWG

Directive 89/336/EEC

EN 60947-5-2 1998+A1: 1999
EN 60825-1: 1994+A1: 2002+A2: 2001
EN 50021: 1999
EN 50281-1-1: 1998+A1: 2002
DMT 02 ATEX ZQS/ E 166

Owen, den

24.10.04

Michael Heyne

(Geschäftsführer / General Manager)

Leuze electronic GmbH + Co KG
In der Braike 1
D-73277 Owen-Teck
Telefon (0 70 21) 57 30
Telefax (0 70 21) 57 31 99
http://www.leuze.de
info@leuze.deDie Gesellschaft ist eine Kommanditgesellschaft
mit Sitz in Owen, Registergericht Kirchheim-Teck, HRA 712
Parschnlich haftende Gesellschafterin ist die
Leuze-electronic Geschäftsführungs-GmbH mit Sitz in Owen
Registergericht Kirchheim-Teck, HRB 550
Geschäftsführer: Michael Heyne (Sprecher), Dr. Harald Grübel
Vorsitzender des Verwaltungsrats: Meinert HahnemannDeutsche Bank AG Stuttgart
Volksbank Kirchheim-Nürtingen
Kreissparkasse Esslingen-Nürtingen
Post giro Stuttgart13 33 624
310 800 005
10 399 220
0 014 890 702(BLZ 600 700 70)
(BLZ 612 901 20)
(BLZ 611 500 20)
(BLZ 600 100 70)Steuer-Nr. 69026 / 10630
USt.-IdNr. DE 145912521

