

HRTR 3B Standard Diffuse reflection light scanner with background suppression

en 11-2010/01 50107304

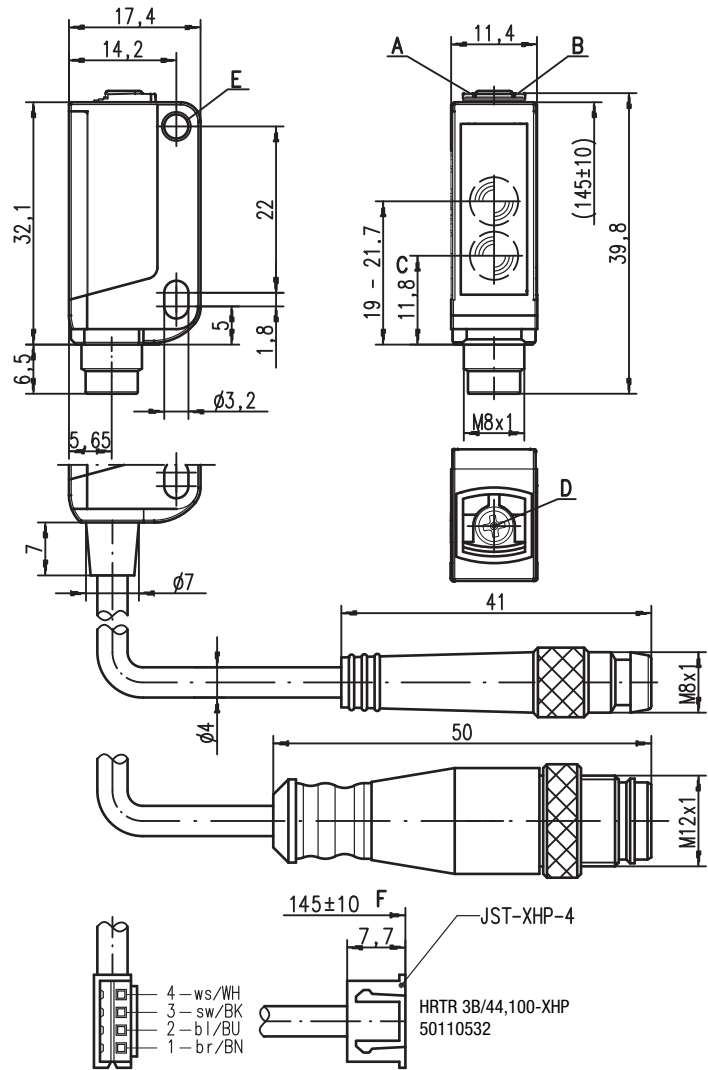

Dimensioned drawing



- A** Green indicator diode
- B** Yellow indicator diode
- C** Optical axis
- D** 8-turn potentiometer for scanning range adjustment
- E** Attachment sleeve
- F** Dimension, incl. device

Electrical connection

Plug connection, 4-pin

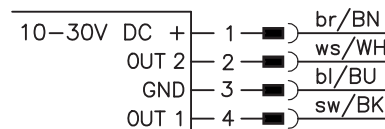

Cable, 4-wire

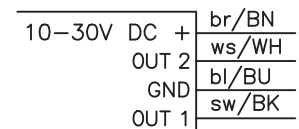

Plug connection, 3-pin

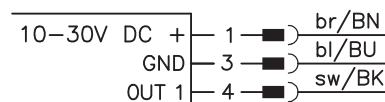

5 ... 400mm
200mm with
black-white error < 10%



- Diffuse reflection light scanner with visible red light and adjustable background suppression
- Exact scanning range adjustment through 8-turn potentiometer
- Very good black/white behavior and reliable switching nearly independent of the object or background properties
- Small and compact construction with robust plastic housing, protection class IP 67/IP 69K for industrial application
- Fast alignment through *brightVision*®
- A²LS- Active Ambient Light Suppression
- Push-pull switching outputs
- High switching frequency for detection of fast events

We reserve the right to make changes • DS_HRTR3B_Standard_en.fm



Accessories:

(available separately)

- Mounting systems (BT 3...)
- Cable with M8 or M12 connector (K-D ...)

Specifications

Optical data

Typ. scanning range limit ¹⁾	5 ... 400mm
Scanning range ²⁾	see tables
Adjustment range ¹⁾	15 ... 400mm
Light beam characteristic	focussed at 200mm
Light source ³⁾	LED (modulated light)
Wavelength	620nm (visible red light)

Timing

Switching frequency	1,000Hz
Response time	0.5ms
Delay before start-up	≤ 300ms (acc. to. IEC 60947-5-2)

Electrical data

Operating voltage U_B ⁴⁾	10 ... 30VDC (incl. residual ripple)
Residual ripple	≤ 15% of U_B
Open-circuit current	≤ 15mA
Switching output	.../66 ⁵⁾ 2 push-pull switching outputs pin 2: PNP dark switching, NPN light switching pin 4: PNP light switching, NPN dark switching
	.../6 ⁵⁾ 1 push-pull switching output pin 4: PNP light switching, NPN dark switching
	.../6D ⁵⁾ 1 push-pull switching output pin 4: PNP dark switching, NPN light switching
	.../44 2 PNP switching outputs, complementary
	.../4 1 PNP switching output light switching, pin 2: not connected ⁶⁾
	.../22 2 NPN switching outputs, complementary light/dark switching
Function characteristics	≥ ($U_B - 2V$) / ≤ 2V
Signal voltage high/low	max. 100mA
Output current	adjustable via 8-turn potentiometer
Scanning range	

Indicators

Green LED	ready
Yellow LED	object detected - reflection

Mechanical data

Housing	plastic (PC-ABS); 1 attachment sleeve, nickel-plated steel
Optics cover	plastic (PMMA)
Weight	with connector: 10g with 200mm cable and connector: 20g with 2m cable: 50g
Connection type	2m cable (cross section 4x0.20mm ²), connector M8 metal, 0.2m cable with connector M8 or M12

Environmental data

Ambient temp. (operation/storage)	-30°C ... +55°C / -30°C ... +70°C
Protective circuit ⁷⁾	2, 3
VDE safety class	II for cable ⁸⁾ , III for metal plug
Protection class	IP 67, IP 69K
LED class	1 (acc. to EN 60825-1)
Standards applied	IEC 60947-5-2
Certifications	UL 508 ⁴⁾

- 1) Typ. scan. range limit/adjustment range: max. achievable scanning range/adjustment range for light objects (white 90%)
- 2) Scanning range: recommended scanning range for objects with different diffuse reflection
- 3) Average life expectancy 100,000h at an ambient temperature of 25°C
- 4) For UL applications: for use in class 2 circuits according to NEC only
- 5) The push-pull switching outputs must not be connected in parallel
- 6) Pin 2: unassigned, hence especially suitable for the connection to AS-interface I/O coupling modules
- 7) 2=polarity reversal protection, 3=short-circuit protection for all transistor outputs
- 8) Rating voltage 50V

Remarks

Adapter plate:

BT 3.2 (Part No. 501 03844) for alternate mounting on 25.4mm hole spacing (Omron E3Z, Sick W100...)

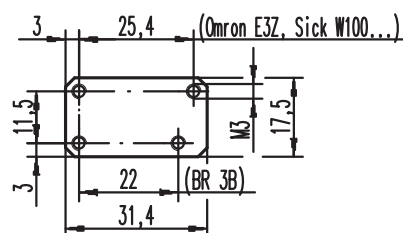

Tables

1	5	400
2	10	300
3	15	200

1	white 90%
2	grey 18%
3	black 6%

□ Scanning range [mm]

Diagrams

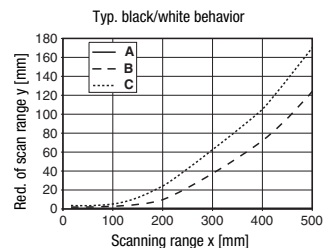
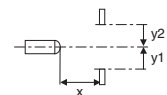
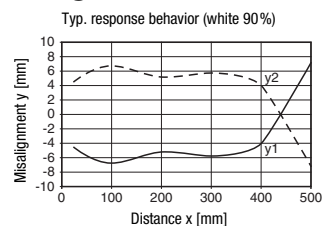

- A white 90%
- B grey 18%
- C black 6%

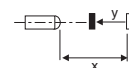

Remarks

Mounting system:

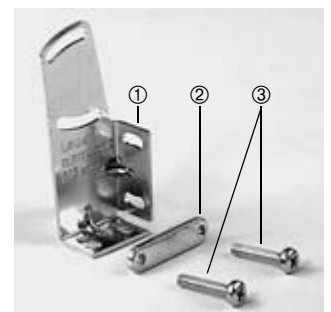

- ① = BT 3 (Part No. 500 60511)
- ②+③ = BT 3.1 ¹⁾ (Part No. 501 05585)
- ①+②+③ = BT 3B (Part No. 501 05546)

1)Packaging unit: PU = 10 pcs.

HRTR 3B Standard Diffuse reflection light scanner with background suppression

Order guide

Selection table			Order code →																					
Equipment ↓			HRTR 3B/66 Part No. 501 07228	HRTR 3B/66-S8 Part No. 501 07229	HRTR 3B/66 200-S8 Part No. 501 07230	HRTR 3B/66, 200-S12 Part No. 501 07298	HRTR 3B/66-S8 Part No. 501 08876	HRTR 3B/6.01-S8 Part No. 501 07231	HRTR 3B/44 Part No. 501 07235	HRTR 3B/44-127-5000 Part No. 501 07234	HRTR 3B/44-S8 Part No. 501 07233	HRTR 3B/44-65-S8 Part No. 501 07237	HRTR 3B/44 200-S12 Part No. 501 07236	HRTR 3B/44, 5000 Part No. 501 09753	HRTR 3B/22 Part No. 501 07238	HRTR 3B/22-S8 Part No. 501 07239	HRTR 3B/6-S8.3 Part No. 501 08408	HRTR 3B/6D, 200-S8.3 on request	HRTR 3B/4, 200-S8.3 Part No. 501 07232	HRTR 3B/44.03, 200-S12 Part No. 501 09486	HRTR 3B/44, 100-XHP Part No. 501 10632			
Output 1 (OUT 1)	push-pull switching output	light switching ○	●	●	●	●	●																	
		dark switching ●																		●				
	PNP transistor output	light switching ○								●	●	●	●	●	●							●	●	●
		dark switching ●																						
	NPN transistor output	light switching ○														●	●							
		dark switching ●																						
Output 2 (OUT 2)	push-pull switching output	light switching ○																						
		dark switching ●	●	●	●	●	●																	
	PNP transistor output	light switching ○								●	●	●	●	●	●								●	●
		dark switching ●																						
	NPN transistor output	light switching ○																						
		dark switching ●																						
Connection	cable 100mm	4-wire																				● 1)		
	cable 2,000mm	4-wire	●						●							●								
	cable 5,000mm	4-wire								●						●								
	M8 connector, metal	3-pin																	●					
	M8 connector, metal	4-pin		●			●				●	●					●							
	M8 connector, metal, snap-on	4-pin						●																
	200mm cable with M8 connector	3-pin																	●	●				
	200mm cable with M8 connector	4-pin			●																			
	200mm cable with M12 connector	4-pin				●								●								● 2)		
	pin 2: not assigned, suitable for connecting to AS-i coupling module								●										●	●	●			
Configura- tion	freely adjustable via 8-turn potentiometer		●	●	●	●		●	●		●		●	●	●	●	●	●	●	●	●	●		
	preset to scanning range [mm]:						80			127		65												
Switching frequency	200Hz		●	●	●	●		●	●		●		●	●	●	●	●	●	●	●	●	●		
	1,000Hz		●	●	●	●		●	●		●		●	●	●	●	●	●	●	●	●	●		

1) With XHP connector: dimensions including device 145mm ± 10mm

2) Connector without Ultra-Lock™ fast locking

Application notes



- **Approved purpose:**

The light scanners are optical electronic sensors for optical, contactless detection of objects.

This product may only be used by qualified personnel and must only be used for the approved purpose. This sensor is not a safety sensor and is not to be used for the protection of persons.

- For glossy surfaces (e.g. metals), the light beam should not be incident on the object surface at a right angle. A slight inclination is sufficient for preventing undesired direct reflections. This may result in a reduction in the scanning range.
- Objects should only be moved in laterally from the right or left. Moving in objects from the connector side or operating side is to be avoided.
- Outside of the scanning range, the sensor operates as an energetic diffuse reflection light scanner. Light objects can still be reliably detected up to the scanning range limit.
- The sensors are equipped with effective measures for the maximum avoidance of mutual interference should they be mounted opposite one another. Opposite mounting of multiple sensors of the same type should, however, absolutely be avoided.