

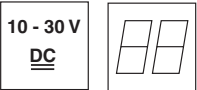

MA 4.7/MA 4D.7

Connector unit for BPS 37



- May be used with BPS 37
- The integrated failure-safe parameter memory for the BPS data (EEPROM) permits exchanging the BPS without reconfiguration
- Integrated two-line display with 16 characters each (MA 4D.7 only)
- Additional RS232 service interface (9-pin sub D connector), operating mode switch service/ standard operation
- Terminals for switching inputs and outputs, including supply voltage
- Rotary switch for setting resolution
- Jumper for gray/binary switching

Dimensioned drawing

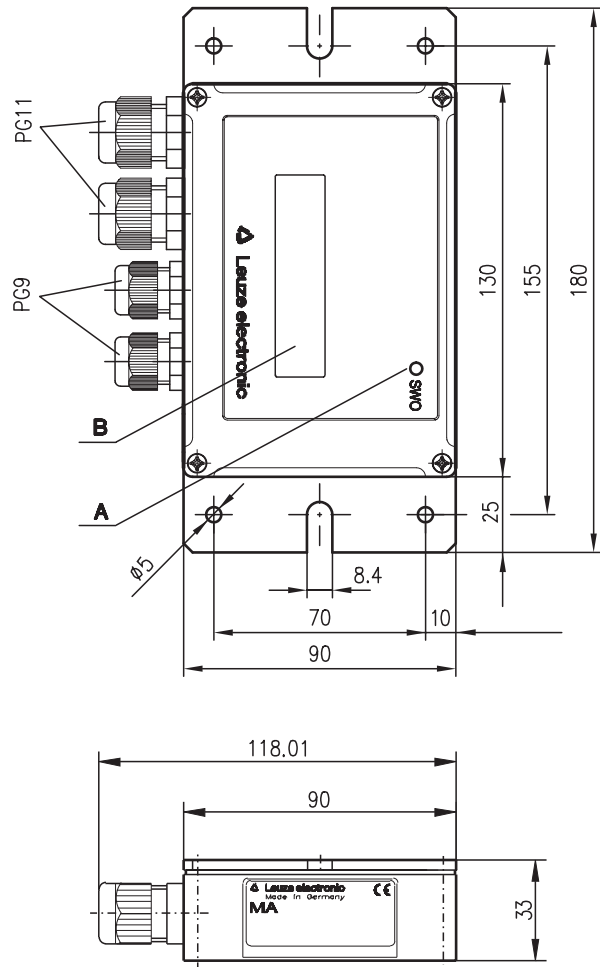

- A LED indicator
- B LCD indicator

Electrical Connection

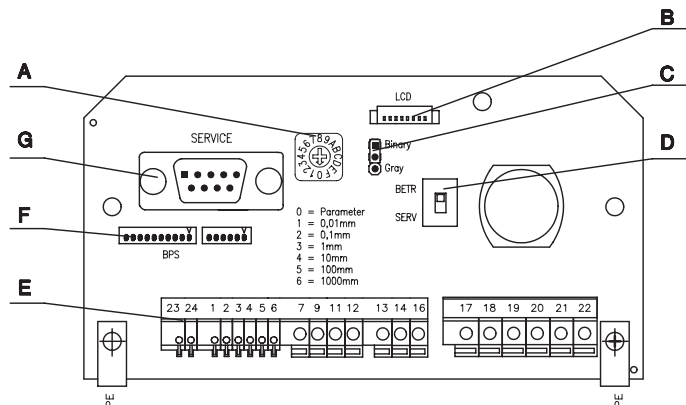

- A Resolution setting
- B Connector for LCD display
- C Gray/binary setting
- D Service/operation switch
- E Terminal strip
- F Connection BPS
- G Service interface

We reserve the right to make changes *MA4_7_MA4D_7_01e.fm



Accessories:

(available separately)

- Bar code positioning system BPS 37
- Cable KB 031-3000 for connecting the connector unit with the BPS 37

Specifications

	MA 4.7	MA 4D.7
Electrical data		
Operating voltage U_B	10 ... 30VDC	
Power consumption	0.2 VA	
Switching input	12 ... 30VDC	
Switching output	$I_{max} = 100mA$ output voltage = operating voltage	
Mechanical data		
Housing	diecast aluminium	
Dimensions	130 x 90 x 33mm (H x W x D)	
Weight	0.665 kg	0.672 kg
Connection type	cable with connector	
Environmental data		
Ambient temp. (operation/storage)	-10°C ... +50°C/-20°C ... +60°C	
Protection class	IP 54	
Valid standards document	IEC 801	
Air humidity	max. 90% rel. humidity, non-condensing	
Indicators		
LED green	switch 1	
Display	-	LCD display – two lines with 16 characters each

Tables

Description

The MA 4.7 or MA 4D.7 is a connector unit for the bar code positioning system BPS 37. It significantly simplifies the electrical installation, commissioning and maintenance of the respective BPS. The figure shows the combination of the connector unit and a BPS 37.

The connector unit permits the storage of the current parameter set in the BPS into a non-volatile EEPROM to protect against power supply disruptions. This has the advantage that the BPS does not have to be reconfigured when it is exchanged. After plug-in, the parameters are loaded automatically into the BPS memory.

The MA 4D.7 D model also has a two-line display with 16 characters each for the display of parameters and operating values.

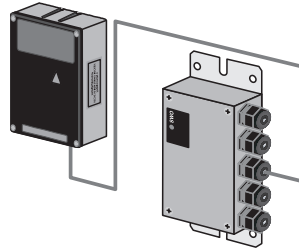

Remarks

The BPS must not be plugged in when the power is on.

Order guide

	Type	Order code
Connector unit for BPS 37 without display	MA 4.7	500 37324
Connector unit for BPS 37 with display	MA 4D.7	500 37325
Connector cable between the BPS 37 and MA 4.7/MA 4D.7	KB 031-3000	500 35355



MA 4.7/MA 4D.7

Operating elements

Rotary switch: setting the resolution

Position	Resolution	Vmax in m/s	Output level	V check
0	Software	Deactivated	Software standard, high = no measurement value	Deactivated
1	0.01 mm	Deactivated	Software standard, high = no measurement value	Deactivated
2	0.1 mm	Deactivated	Software standard, high = no measurement value	Deactivated
3	1 mm	Deactivated	Software standard, high = no measurement value	Deactivated
4	10 mm	Deactivated	Software standard, high = no measurement value	Deactivated
5	100 mm	Deactivated	Software standard, high = no measurement value	Deactivated
6	1000 mm	Deactivated	Software standard, high = no measurement value	Deactivated
7	Software	0.7	Below Vmax = high, no values = low, above Vmax = low	Active
8	Software	2	Below Vmax = high, no values = low, above Vmax = low	Active
9	Software	3	Below Vmax = high, no values = low, above Vmax = low	Active
A	Software	4	Below Vmax = high, no values = low, above Vmax = low	Active

Function

If the set speed limit is exceeded, the switching output is deactivated.
 If the BPS cannot measure the speed (i.e. no measurement values can be recorded), the switching output is deactivated.
 The output is fail safe, i.e. the unit functions correctly as long as the switching output is high.

Adjusting parameters

All parameters which are not affected by the switch position can be changed.
 For example, in switch position 7, 8, 9 or A the resolution can be changed using the "BPS Config" program or the switching output can be inverted.

Jumper

Gray/binary switching

Interface mode

DIP switch

SERV: service interface active/ host interface deactivated
 BETR: Host interface active

Service connector

Sub-D connector, 9 pin

RS 232 interface for service/setup operation
 Default data format: 9600 Baud, 8 data bits, 1 stop bit, no parity (adjustable)
 2=RxD, 3=TxD, 5=GND

Connector for BPS 37

PCB connector

connection for the BPS 37

SSI interface

Terminals 1/2
 Terminals 3/4
 Terminal 13
 Terminal 7

SSI Data +
 SSI Data -
 SSI Clock +
 SSI Clock -

Switched input

Terminal 9
 Terminal 11
 Terminal 12

SE1 - switching input 1, 12 ... 30VDC
 VDD_SE - supply voltage switching input, equal to V_IN device
 GND_SE - supply voltage switching input, equal to GND_IN device
 12 ... 30VDC switching input asymmetric to GND

Switching output

Terminal 14
 Terminal 16

SA1 - switching output 1
 GND_SA – external supply voltage switching output 0VDC
 Load must be connected asymmetrically to GND.
 The switching voltage for the output is generated by the operating voltage V_IN:
 VDD_SA = VDD_IN
 GND_SA = GND_IN

Operating voltage

Terminals 17-18
 Terminals 19-20
 Terminals 21-22

Connection terminals for the operating voltage of the MA 4.7 (10 ... 30VDC) and for the BPS used.
 Dual design of the voltage supply connections for insertion or for the supply of further components.
Attention! PE must be connected for interference rejection!
 V_IN operating voltage 10 ... 30VDC
 GND_IN operating voltage 0VDC
 PE protective earth, grounding

Circuitry of the connector unit

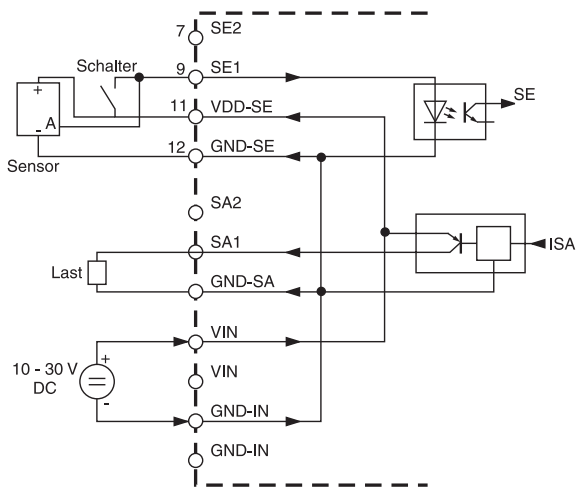

Indicators

A LED labelled "SWO" is located on top of the connector unit. It indicates the state of the switching output 1. In addition, the MA 4D.7 features the 2 x 16-character LCD display.

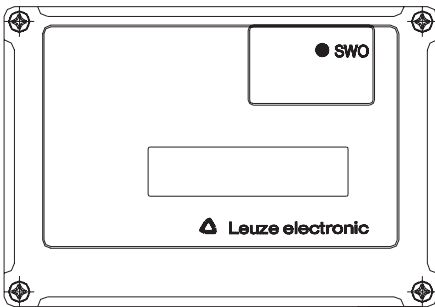

In the standard setting, the LED indicates that no positioning data can be identified. Please refer to the Technical Description BPS 37 for further states of the switching output.

Operating the MA 4D.7 LCD display

If the LCD display is configured and ready for operation, the required information such as position is shown automatically. In the standard setting, the indicated value is displayed intermittently.

Notice:

If the CCD output interval is reduced using the "BPS Config" program, the output rate at the SSI interface is also reduced.