



MA 4 1xx / MA 4 1xx L / MA 4D 1xx

Connector unit for BCL 22 and BCL 32



- May be used with BCL 22 and BCL 32
- The integrated failure-safe parameter memory for the BCL data (EEPROM) permits exchanging the BCL without reconfiguration
- Integrated two-line display with 16 characters each (MA 4D 1xx only)
- Networking of several BCL 22/32 via RS485 interface, hardware addressing in Leuze multiNetplus (MA 4x 100 only)
- Additional RS232 service interface (9-pin sub D connector), operating mode switch service/standard operation
- Terminals for switching inputs and outputs, including supply voltage
- Several interface modules available (electrically insulated):
 - RS 485
 - RS 232
 - TTY
 - RS 422



Accessories:

(available separately)

- Bar code readers BCL 22 and BCL 32
- Cable KB 031-3000 for connecting the connector unit MA 4/MA 4D with the BCL 32
- Cable KB 040 for connecting the connector unit MA 4L with the BCL 32

Dimensioned drawing

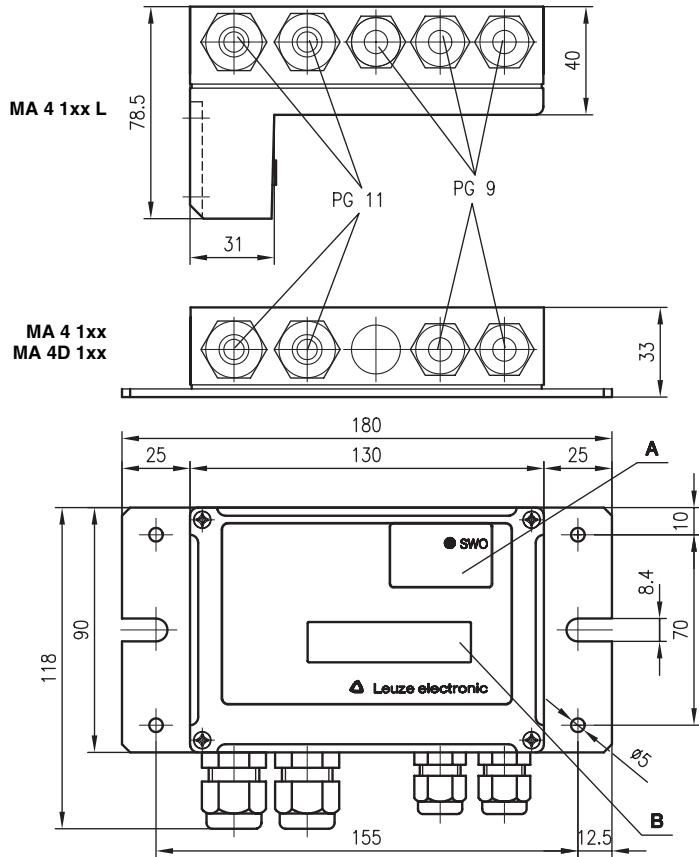

- A LED indicator
- B optional LCD indicator

Electrical Connection

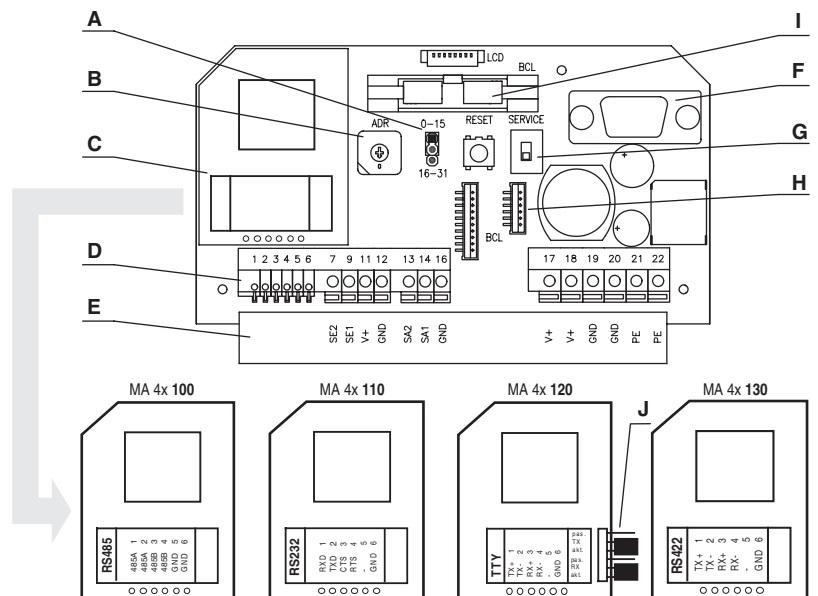

- A Device address adjustment 0-15 or 16-31
- B Setting of the device address
- C Interface module
- D Terminal strip
- E Attached label with terminal designation
- F Service interface
- G Service/operation switch
- H Connection BCL
- I Cover Connection (MA 4 1xx L)
- J Jumper TTY active/passive (MA 4x 120 ... only)

We reserve the right to make changes •

MA 4 1xx / MA 4 1xx L / MA 4D 1xx
Specifications

	MA 4 1xx	MA 4 1xx L	MA 4D 1xx
Electrical data			
Operating voltage U_B	10 ... 30VDC		
Power consumption	0.2VA		
Switching input	12 ... 30VDC		
Switching output	$I_{max} = 100\text{mA}$, output voltage = operating voltage		
Mechanical data			
Housing	diecast aluminium		
Weight	480g	585g	490g
Connection type	cable with connector KB 031	cable with connector KB 040	cable with connector KB 031
Environmental data			
Ambient temp. (operation/storage)	-10°C ... +50°C/-20°C ... +60°C		
Protection class	IP 54		
Valid standards document	IEC 801		
Air humidity	max. 90% rel. humidity, non-condensing		
Indicators			
LED green	switch 1		
Display	–	–	LCD display – two lines with 16 characters each

Tables
Description

The MA 4 1xx, MA 4 1xx L or MA 4D 1xx is a connector unit for the bar code readers BCL 22 and BCL 32. It significantly simplifies both the electrical installation and the commissioning and maintenance of the respective BCL. In addition, it permits the networking of several bar code readers. The figure shows the combination of the connector units and a BCL device.

The connector unit permits the storage of the current parameter set in the BCL into a non-volatile EEPROM to protect against power supply disruptions. This has the advantage that the BCL does not have to be reconfigured when it is exchanged. After plug-in, the parameters are loaded automatically into the BCL memory.

The MA 4D 1xx model also has a two-line display with 16 characters each for the display of parameters and operating values. According to your preferences, one or two results may be displayed. The various display modes are stored in the parameter set of the BCL.

All BCL 22 models with PCB connector from software version 02.00 onwards or all BCL 32 models together with a corresponding cable and a cable length of up to 3m may be connected to the MA 4 1xx/MA 4D 1xx. At the MA 4 1xx L, the BCL 32 can be directly plugged in via a sub-D connector. The data are coded in the BCL identifier as follows:

BCL 22 XYZ

The connector type is coded at the **X** location: **X** = 2: PCB connector, **X** = 3: Sub D connector

The length of the connection cable used is coded at the **Y** location:

Y = 0: 0.8m connection cable

Y = 1: 3m connection cable

The BCL 32 is connected directly or via KB 040 to the MA 4 1xx L, or via KB 031 3000 to the MA 4 1xx or MA 4D 1xx.

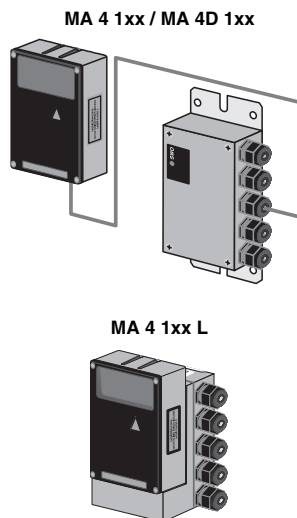
Remarks

The BCL must not be plugged in if the power is on.

**MA 4 1xx / MA 4 1xx L / MA 4D 1xx****Order guide**

	Interface module	Type	Order code
Connector unit for BCL 22 and BCL 32 without display	RS 232	MA 4 110	500 39659
	TTY	MA 4 120	500 39660
	RS 422	MA 4 130	500 39661
Connector unit for BCL 22 and BCL 32, for direct plug-in of the BCL, without display	RS 485	MA 4 100 L	500 39655
	RS 232	MA 4 110 L	500 39656
	TTY	MA 4 120 L	500 39657
	RS 422	MA 4 130 L	500 39658
Connector unit for BCL 22 and BCL 32 with display	RS 232	MA 4D 110	500 39662
	TTY	MA 4D 120	500 39663
	RS 422	MA 4D 130	500 39664

Operating elements**Setting the network address**

Rotary switch
Jumper

position 0: standalone device, position 1 to F: multiNet slave address
top: low address range 0 ... 15, bottom: high address range 16 ... 31

Interface mode

DIP switch

SERV: service interface active / host interface deactivated, BETR: host interface active

Service connector

Sub-D connector, 9 pin

RS 232 interface for service/setup operation
standard data format: 9600 baud, 8 data bits, 1 stop bit, no parity, 2=Rx, 3=Tx, 5=GND

Connector for BCL 22, BCL 32

PCB connector

connection for the BCL

RS 485 interface module

Terminals 1-2
Terminals 3-4
Terminals 5-6

The RS 485 interface connections are implemented twice, for insertion.
The RS 485 interface is floating.
RS 485A (line A)
RS 485B (line B)
RS 485 GND

RS 232 interface module

Terminal 1
Terminal 2
Terminal 3
Terminal 4
Terminal 6

The RS 232 interface is floating.
Rx
Tx
CTS
RTS
GND

TTY interface module

Terminal 1
Terminal 2
Terminal 3
Terminal 4
Terminal 6

The operating mode active/passive is selected via the two jumpers on the TTY interface module.
The TTY interface is floating.
TX+
TX-
RX+
RX-
GND

RS 422 interface module

Terminal 1
Terminal 2
Terminal 3
Terminal 4
Terminal 6

The RS 422 interface is floating.
TX+
TX-
RX+
RX-
GND

Switching inputs

Terminal 7
Terminal 9
Terminal 11
Terminal 12

SE2 – switching input 2, 12 ... 30VDC
SE1 - switching input 1, 12 ... 30VDC
VDD_SE - supply voltage, switching input, equal to V_IN device
GND_SE - supply voltage, switching input, equal to GND_IN device
12 ... 30VDC switching input asymmetric to GND

Switching outputs

Terminal 13
Terminal 14
Terminal 16

SA2 – switching output 2
SA1 - switching output 1
GND_SA – external supply voltage switching output 0VDC
Load must be connected asymmetrically to GND.
The switching voltage for the output is generated by the operating voltage V_IN:
VDD_SA = VDD_IN, GND_SA = GND_IN

Operating voltage

Terminals 17-18
Terminals 19-20
Terminals 21-22

Connection terminals for the operating voltage of the MA 4 (10 ... 30VDC) and for the BCL used.
Dual design of the voltage supply connections for insertion or for the supply of further components.
Attention! PE must be connected for protection against faults!
V_IN operating voltage 10 ... 30VDC
GND_IN operating voltage 0VDC
PE protective earth, grounding

Circuitry of the connector unit

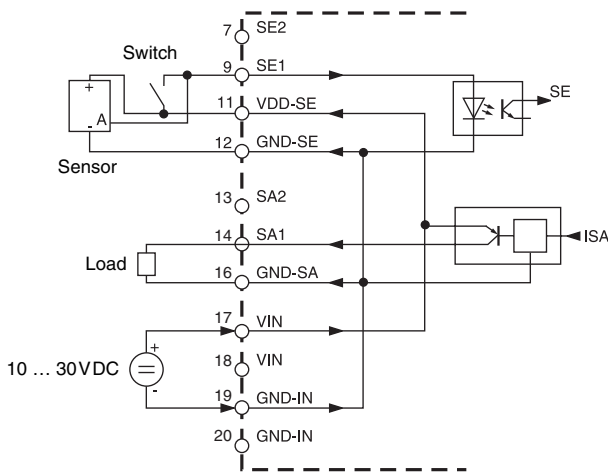

Indicators

A LED labelled "SWO" is located on top of the connector unit. It indicates the state of the switching output 1. In addition, the MA 4D 1xx features the 2 x 16-character LCD display.

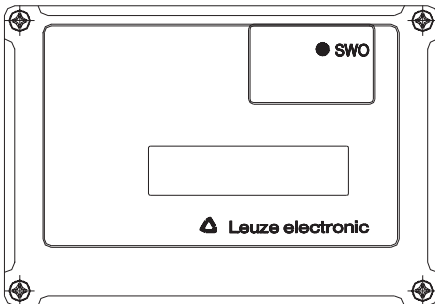

In the standard setting, the LED indicates the decoding of a bar code.

Please refer to the Technical Description BCL 21/22 or BCL 31/32 for further states of the switching output.

Operating the MA 4D 1xx LCD display

If the LCD display is configured and ready for operation, the required information such as data read, software version, or status displays is shown automatically.

Format

The LCD display contains two lines with 16 characters each. There are 3 display modes:

1. Single line:
a result is output in one line. If the information is longer than 16 characters, the characters > 16 are cut off. This means that two results may be output on the LCD display.
2. Double line:
a result is displayed over both lines. Thus, only one result is visible in the display.
3. Depending on the size:
if a result is > 16 characters, both lines are used
if a result is < 16 characters, one line is used and two results are displayed

Address	Size	Designation	Range of values	Standard
161	byte	lcd_output_format	1: single line (two results) 2: double line (one result) 0: depending on the size	2: double line (one result visible)

The input can be specified as a PT commentary or in the BCL Config parameter list, e.g., PT0001610x.

Text output

If a text from the controller is to be output to the MA 4D 1xx, the following command must be used. The text is output in the preselected line format.

Command: **M[Text]**

e.g.: if the text "input" is to be output to the LCD display, the command is: **Minput**