

## MA 208i Ethernet TCP/IP Gateway

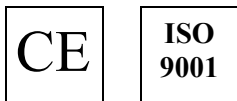

## Ethernet TCP/IP Gateway



### Features

- Connector unit for Leuze RS 232 devices to Ethernet TCP/IP
- Plug and Play by easy connection and configuration
- Integrated Switch
- Easy connection via M12 connector
- Protection Class IP 65

### Specifications

#### Electrical data

Operation voltage 18 ... 30 VDC  
Maximum current max. 3A

#### Connection

Fieldbus (HOST) Ethernet TCP/IP  
Device RS 232  
Connection type 2 x M12 – Ethernet TCP/IP  
1 x connector – RS232  
1 x M12 – Power IN / GND and SWIO  
1 x M12 – Power OUT / GND and SWIO

#### Connector pin assignment



#### Protocols

TCP/IP Server and Client Mode  
UDP

#### Mechanical data

Housing diecast aluminum  
Dimensions (H x W x D) 130 x 90 x 41mm  
Weight 0,7 kg  
Protection class IP 67

#### Environmental data

Temperature (operation) 0 ... 55°C  
Temperature (storage) -20°C ... 60°C  
Air humidity max. 90% rel. Humidity, non-condensing

#### Indicators

LINK0 , RX/TX0  
LINK1 , RX/TX1  
Com  
Power

## Device support

**MA 208*i***

Following devices are supported by the Ethernet TCP/IP Gateway and can be selected by the device switch on the board. Corresponding connection cables are available. The Ethernet TCP/IP Gateway is parameterized by the device switch to the according Leuze device. A configuration is not necessary.

### Device switch:

Pos	Leuze Periphery
0	Default Setting
1	BCL 8
2	BCL 22
3	BCL 32
4	BCL 500i
5	BCL 90
6	LSIS 120
7	LSIS 400
8	Hand-held scanner
9	RFID (RFI xx, RFM xx, RFU xx)
10	BPS 8 / 32
11	AMS
12	MA 3x
13	other RS 232 devices

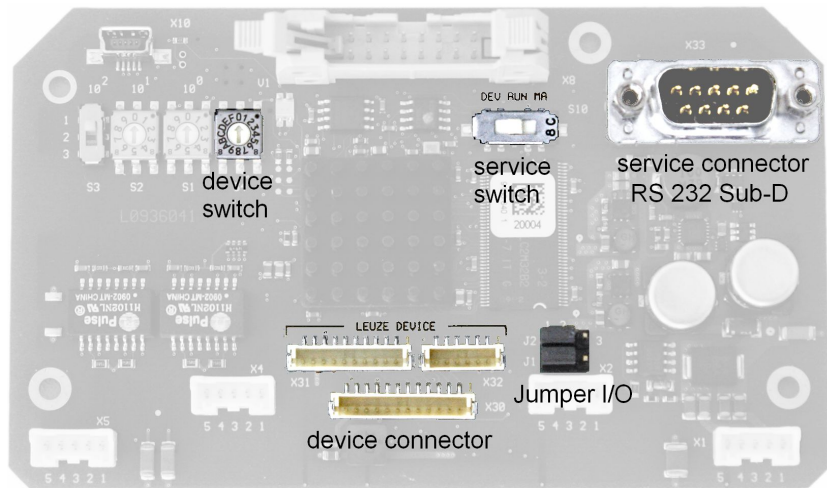

### other Features:

- Service switch for configuration MA 208*i* and Leuze device via RS 232
- Jumper I/O to control multiple MA 208*i* at the same time via trigger signal
- Device connector for direct connection of Leuze devices

## Order guide

Type		Order code
MA 208 <i>i</i> Ethernet TCP/IP Gateway	RS232 - Ethernet TCP/IP	50112892
MA 248 <i>i</i> PROFINET Gateway	RS232 - PROFINET-IO RT	50112891
MA 204 <i>i</i> PROFIBUS Gateway	RS232 - PROFIBUS	50112893