

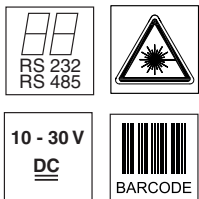

Part No. 501 07795



- Scanning rate 1000scans/s (M-Optics)
- Automatic detection of code type and code quality
- Raster scanner or single-line scanner versions
- Parameters are stored fail-safe
- Reference code comparison function
- Interfaces are freely configurable
- Up to 2 switching inputs and 2 switching outputs each
- Simple mounting and fastening
- Integrated multiNet and daisy-chain network functionality



Accessories:

(available separately)

- Mounting systems (BT ...)
- Modular connector units MA ... (see separate data sheets)

Dimensioned drawing

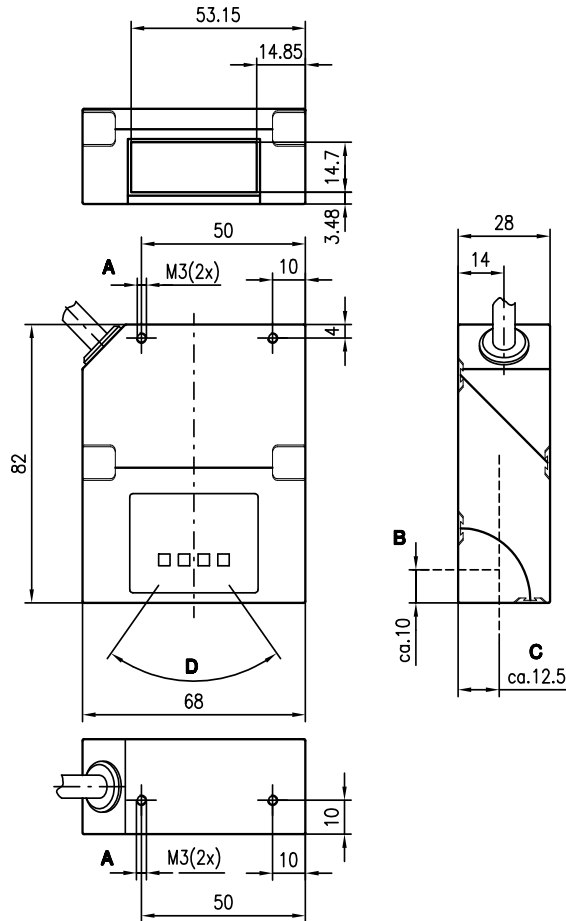

- A Mounting thread with thread depth of max. 4mm
- B Optical axis (perpendicular beam exit - 90°)
- C Optical axis (straight beam exit - 0°)
- D Laser beam, opening angle adjustable

Electrical connection

Cable with Sub-D connector

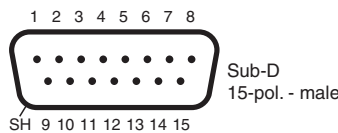

PIN	BCL 21 Signal	BCL 22 Signal
1	RS 485 GND	Res.
2	SWIN1	SWIN1
3	RS 485 A	RS 232 CTS
4	RS 485 B	RS 232 RTS
5	/MA0	Res.
6	/MA1	SWOUT2
7	/Serv	/Serv
8	VIN	VIN
9	/MA4	SWIN2
10	SWOUT1	SWOUT1
11	RxD_Serv	RS 232 RxD
12	TxD_Serv	RS 232 TxD
13	/MA2	Res.
14	/MA3	Res.
15	GNDIN	GNDIN
SH	Shield	Shield

Cable with 2 system connectors



PIN	Colour	BCL 21 Signal	BCL 22 Signal
ZHR10			
1	br/BN	RS 485 GND	Res.
2	rt/RD	RS 485 A	RS 232 CTS
3	or/OG	RS 485 B	RS 232 RTS
4	ge/YE	RxD_Serv	RS 232 RxD
5	gn/GN	TxD_Serv	RS 232 TxD
6	bl/BU	/Serv	/Serv
7	vi/VI	SWIN1	SWIN1
8	gr/GY	VIN	VIN
9	ws/WH	GNDIN	GNDIN
10	SH	PE	PE
ZHR6			
1	ws-br/WH-BN	/MNA0	Res.
2	ws-rt/WH-RD	/MNA1	SWOUT2
3	ws-or/WH-OG	/MNA2	Res.
4	ws-ge/WH-YE	/MNA3	Res.
5	ws-gn/WH-GN	/MNA4	SWIN2
6	ws-sw/WH-BK	SWOUT1	SWOUT1

We reserve the right to make changes * bcl_21_22_gb_fm



Specifications

Optical data

Light source laser diode, red, approx. 650nm
 Laser class class 2 acc. to EN 60825-1, class II acc. to 21 CFR 1040.10 with Laser Notice No. 50
 Resolution / scanning rate N-Optics: m = 0.15mm ... 0.5mm / 800 scans/s
 M-Optics: m = 0.2mm ... 0.8mm / 1000 scans/s
 F-Optics: m = 0.5mm ... 1.0mm / 800 scans/s
 Beam deflection by means of rotating polygon mirror wheel
 Read distance 50 ... 450mm (depending on type of optics: see reading curves)
 Reading field opening 70mm at 50mm distance
 Grid (R1) 10 lines
 Grid field the distance from the first to the last laser beam is specified in relation to the distance to the scanner:
 16mm at a scanner distance of 100mm,
 29mm at a scanner distance of 200mm,
 42mm at a scanner distance of 300mm,
 55mm at a scanner distance of 400mm
 Optical window glass with scratch-resistant Indium coating
 Code types 2/5 Interleaved, Code 39, Code 93, Code 128, EAN 128, EAN/UPC, EAN Adendum, Codabar, Pharma Code

Electrical data

Interface type BCL 21: RS 485
 BCL 22: RS 232
 Baud rate adjustable: 110 ... 115200Bd
 Data formats data bits: 7, 8, 9
 parity: None, Even, Odd
 Stop bit: 1, 2
 Service interface RS 232 with fixed data format, 9600Bd
 8 data bits, no parity, 1 stop bit
 Ports BCL 21: 1 switching output, 1 switching input
 BCL 22: 2 switching outputs, 2 switching inputs
 Operating voltage 10 ... 30VDC
 Power consumption max. 3.2W

Mechanical data

Protection class IP 65
 Weight 180g/260g with cable
 Dimensions (W x H x D) 82x68x28mm
 Housing plastic ABS / PC

Environmental data

Ambient temp. (operation/storage) 0°C ... +40°C/-20°C ... +60°C
 Air humidity max. 90% rel. humidity, non-condensing
 Vibration IEC 60068-2-6, test FC
 Shock IEC 60068-2-27, Test Ea
 Repeated shock IEC 60068-2-29, test Eb
 Electromagnetic compatibility EN 55022, IEC 61000-4-2, -3, -4 and -6
 Certificates CE, UL

LED displays

LED name	PWR/Ready	ERR/Error	DEC/Decode
LED colour	green	red	yellow
State			
No voltage	off	off	off
Initialisation (after reset)	flashing (cycle 1)	off	off
System ready	on	off	off
Reading gate active	on	off	on
Hardware error (defective motor, defective laser, defective system, etc.)	off	on	-
autoConfig/teach-in	flashing (cycle 1)	flashing (cycle2)	-
Service interface active	on	flashing (cycle2)	-



Notice!

The flashing frequency is 5Hz; cycle2 is inverse to cycle 1.

Tables

Diagrams

Remarks



AVOID EXPOSURE - LASER LIGHT IS EMITTED FROM THIS APERTURE
 CAUTION: LASER LIGHT WHEN OPEN
 DO NOT STARE INTO BEAM

LASER LIGHT - DO NOT STARE INTO BEAM
 CLASS 2 LASER PRODUCT
 Maximum output: 1.3mW
 Pulse duration: 70µs
 Emitted wavelength: 650..690nm
 EN 60825-1: 2003-10
 CLASS II LASER PRODUCT
 Maximum output: 1.3mW
 Pulse duration: 35µs
 Emitted wavelength: 650..690nm
 Complies with 21 CFR 1040.10



Reading curves

BCL 21/22 with N-Optics and 800scans/s

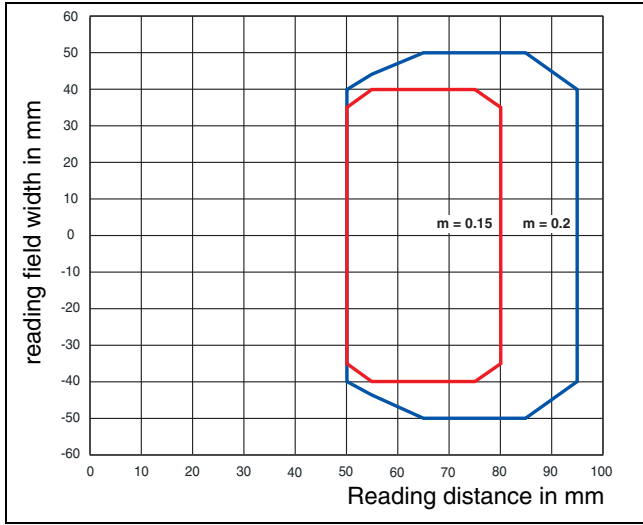

BCL 21/22 with M-Optics and 1000scans/s

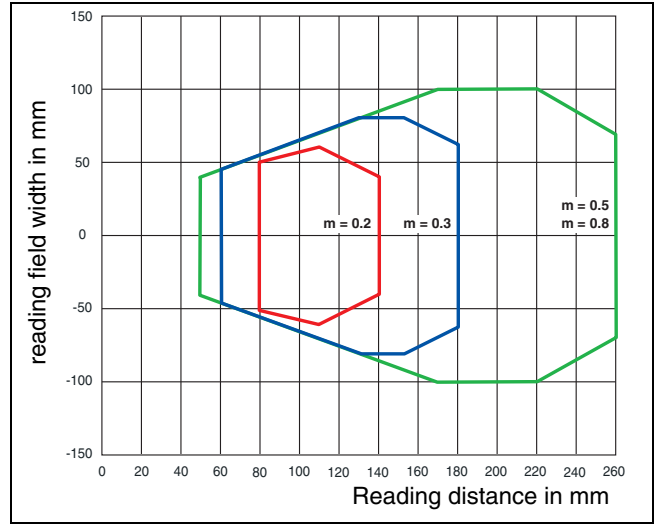

BCL 21/22 with F-Optics and 800scans/s

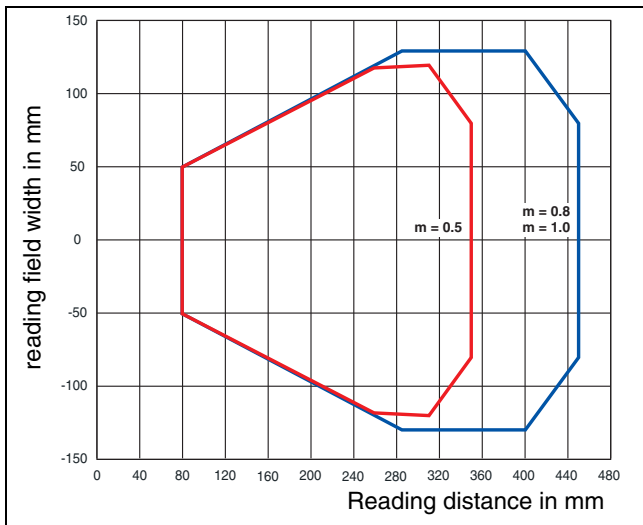



Type key

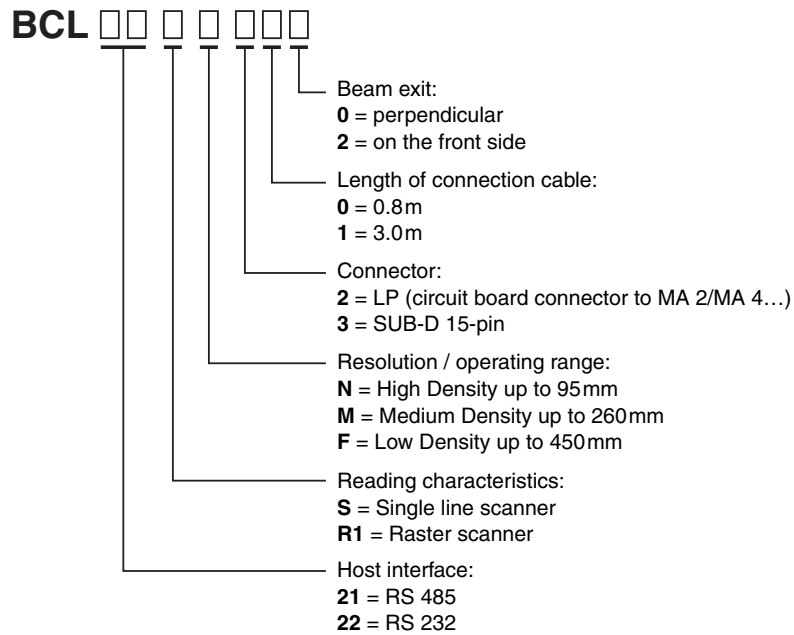

Order guide and accessories



See technical description and/or price list!