

ROBUST RRT 24.1

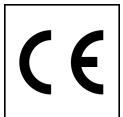

Multiple Light Beam Safety Device (Type 2 AOPD)

ROBUST Multiple Light Beam Safety Devices in combination with a test monitoring unit (safety interfaces, MSI, TNT 35 or TMC 66) are type 2 active opto-electronic devices (AOPD) in accordance with IEC/EN 61496-1 and 2. RRT 24.1 is a 4-beam Multiple Light Beam Safety Device with a beam distance of 300 mm with integrated transmitter and receiver systems. It forms a functional unit in combination with a passive deflecting mirror, PM4-300 or PM4-300V.



Leuze electronic GmbH + Co. KG
 Liebigstrasse 4
 82256 Fuerstenfeldbruck / Germany
 Phone +49 8141 5350-0
 Telefax +49 8141 5350-190
 info@leuze.de
 www.leuze.com

Features

- Switching output: pnp transistor output
- Beam distance, 300 mm (in acc. with EN 999)
- Durable, torsion-resistant aluminum profile
- Integrated optics heating for use at low temperatures
- Glass optics with spacing bolts for mounting laser alignment aid
- Compact profile with integrated fixing slot
- Positionable M6 sliding nuts for fast mounting
- Activation input for testing and connection in series
- EC prototype certified safety component in accordance with IEC/EN 61496-1 and 2
- M12 connection

Electrical connection

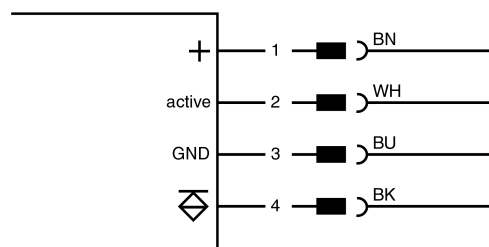

Dimensional drawing

ROBUST RRT 24.1

Passive deflecting mirror, PM4 (accessory)

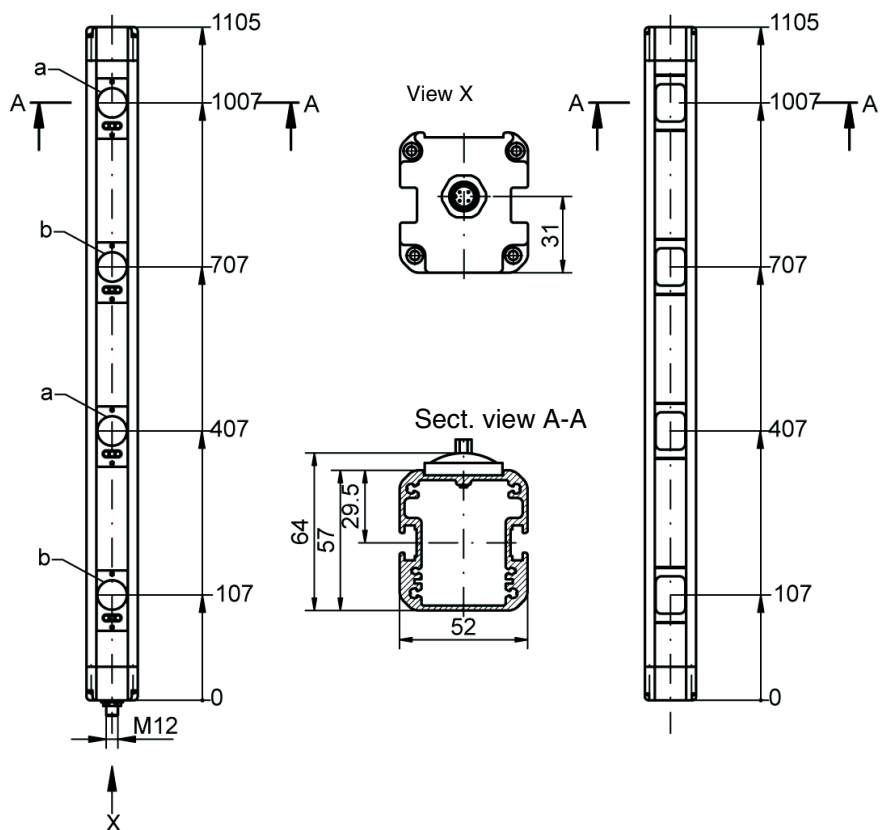

a = Transmitter
 b = Receiver

Technical data

Safety type in accordance with IEC/EN 61496:	Type 2 in combination with a Safety Interface Device or a Test Monitoring Unit	
Beam distance	300 mm	
Range ¹⁾	With PM4-300:	0,5 - 2,5 m
	With PM4-300V:	1,5 - 8 m
Sensor response time	12 ms	
Supply voltage, U _a	24 V DC, ± 15 %	
Residual ripple	≤ 15% of U _a	
Protection class	III	
Protection rating	IP 67	
Ambient temperature, operation	-25...+55 °C	
Ambient temperature, storage	-30...+70 °C	
Weight (depending on length)	1.80 kg	
Housing	Extruded aluminum profile	
Color	RAL 1021, yellow (lead and cadmium-free)	
Optics	Glass with optics heating	
Installation position	Any	
Fixing	With M6 sliding nuts, positionable	
Power consumption	Approx. 160 mA without external load	
Connection technology	M12 plug 5-pin, B-coded	
Transmission element		
Transmitter diodes, class in acc. with EN 60825	1	
Wavelength	880 nm	
Light source	LED, infrared (floating light)	
LED yellow	Transmitter activated	
Test activation, T _A (high active)	Transmitter active ≥ 3 mA Transmitter inactive ≤ 1 mA Input resistance 5 kΩ Test-Response time ≤ 400 μs	
Reception element		
Safety-related switching output (OSSD) ²⁾	pnp transistor output (short-circuit-proof)	
Output current	Max. 200 mA	
Function	Light on	
LED red	Light path interrupted	
LED green, flashing	Light path free, no functional reserve	
LED green	Light path free, with functional reserve	

1) Operating range: Recommended range with functional reserve

2) 1 = transient protection, 2 = reverse-connect protection, 3 = short-circuit protection for all outputs

Notes

The Multiple Light Beam Safety Device is an active opto-electronic device (AOPD) in combination with a safety-related control system a machine to be protected, in which the transmitter and receiver are cyclical tested in accordance with IEC/EN 61496-1. Suitable in this respect are, for example, the safety interfaces of the MSI family or the test monitoring units, TNT 35 and TMC 66.

The power supply to which the Multiple Light Beam Safety Device is connected must intercept changes and interruptions of the supply voltage in accordance with IEC/EN 61496-1.

Testing

In operating status the activation input on the transmitter is switched to high active (24 V DC). The input is briefly switched off for testing (≤ 2 V, at least 10 ms). The receiver then also switches off briefly. This function test is evaluated accordingly from the test monitoring unit. The monitoring of the control line to the transmitter and the output line from the receiver is also an additional advantage of this test method.

Ordering information

RRT 24.1 supply schedule:

- 1 RRT 24.1 transceiver
- 1 BT-S brackets
- 1 connecting and operating instructions manual

Note: A PM4-300 or PM4-300V is required for the function (see accessories)

Order numbers

Item no.	Item
50081465	ROBUST RRT 24.1

1 BT-S brackets are included in the supply schedule

Accessories

MSI

Safety interfaces, e.g. with muting functions

TNT 35

Test monitoring unit with integrated cyclical test interval – 2 seconds

TMC 66

Test monitoring unit with integrated muting function and permanent cyclical testing

- Mounting accessories with mounting bracket
- UDC mounting columns
- Laser alignment aid: LA 78, LA 78U, LA 78UDC
- Passive deflecting mirror: PM4-300/PM4-300V
- UMC deflecting mirror columns

Order numbers

Item no.	Item
Test monitoring unit	
50033058	TNT 35
50082121	TMC 66
Mounting accessories	
560120 ¹⁾	BT-S
560300 ²⁾	BT-SSD
Mounting columns	
549810	UDC-1000
549813	UDC-1300
Laser alignment aids	
549000	LA-78
560020	LA-78U
520004	LA-78UDC
Passive deflecting mirror	
50029570	PM4-300
909663	PM4-300V
Deflecting mirror column	
549704	UMC-1304

1) Standard bracket included in supply schedule

2) 2 pieces required for RRT 24.1