

MSI-mxE/Rx.2



Additional information to the safety interface MSI-mxE/Rx.2 for type 2 sensors

The modular safety interface components of the MSI family serve as connecting links between one or more optoelectronic protective devices and the machine controls. The individual versions offer various safety-related additional functions, such as start/restart interlock, EDM (external device monitoring), test monitoring of type 2 sensors, single break/double break control, or muting. MSI-mxE/Rx.2 contains relay outputs.

The "E" versions are designed for use in operating temperatures up to 55° Celsius.

The differences in the technical specifications of the MSI-mxE safety interfaces from the standard MSI-mx version are described in this datasheet.

Advantages of the MSI-mxE/Rx.2 special version

- Safety interface of type 2, with muting function in accordance with IEC-, EN 61496-1, EN 954-1
- 2-8 type 2 AOPDs can be connected.
- designed for operating temperatures up to 55° Celsius
- UL-Certification in preparation

Ordering Information

Type	Art. no.
MSI-mxE/Rx.2	549984
MSI-AC 115 (power supply 24 V DC, 0,8 A)	549940
MSI-AC 230 (power supply 24 V DC, 0,8 A)	549908
/Rx output subassembly (replacement part)	590211
MSI diagnostic set MSI-SWC	549932
MSI-AC-TD1 Time Delay Element	549985

Leuze electronic GmbH + Co. KG

Liebigstrasse 4

D-82256 Fuerstenfeldbruck

Tel: +49 8141 5350-0

Fax: +49 8141 5350-190

E-Mail: info@leuze.de

www.leuze.com

MSI-mxE/Rx.2



Important note!

Please note the following differences from the MSI-mx/Rx Connecting and Operating Instructions:

The following connection combinations are possible at inputs S1 to S4.

		Jumper
a)	T1 → AOPD → S2 and T2 → AOPD → S1	S1/S3 + S2/S4
b)	T1 → AOPD → S4 and T2 → AOPD → S3	S1/S3 + S2/S4
c)	a) and b)	—
d)	T1 → AOPD → S2 and T1 → AOPD → S4	—
	T2 → AOPD → S1	S1/S3
e)	T1 → AOPD → S2	S2/S4
	T2 → AOPD → S1 and T2 → AOPD → S3	—

In the MSI-mxE/Rx.2 special variant the safety input channels are designed to take only AOPD **type 2** sensors.

The inputs 25, 26, 34, 35 are not used. When putting the Safety interface MSI-mxE/Rx.2 into operation, you should be familiar with the Connecting and Operating Instructions for the MSI-mx, as well as with the datasheet containing additional information for the MSI-mxE/Rx.2

Technical data for the MSI-mxE/Rx.2 special version

OSSD* response time of the MSI-mxE/Rx.2 (without AOPD) AOPD Typ2	64 ms
OSSD* reset time	300 ms
Ambient operating temperature	0° ... +55°
Certifications	BIA, cUL ist beantragt

*) OSSD: Safety related switching output (Output Signal Switching Device)

For all other technical data see MSI-mx operating instructions, chapter 6!



This datasheet includes supplementing technical specifications which are different from the technical specifications for the MSI-mx standard version. Please consult the technical specifications for the standard versions, chapter 6, in the Connecting and Operating Instructions for the MSI-mx safety interfaces.

Electrical Connection

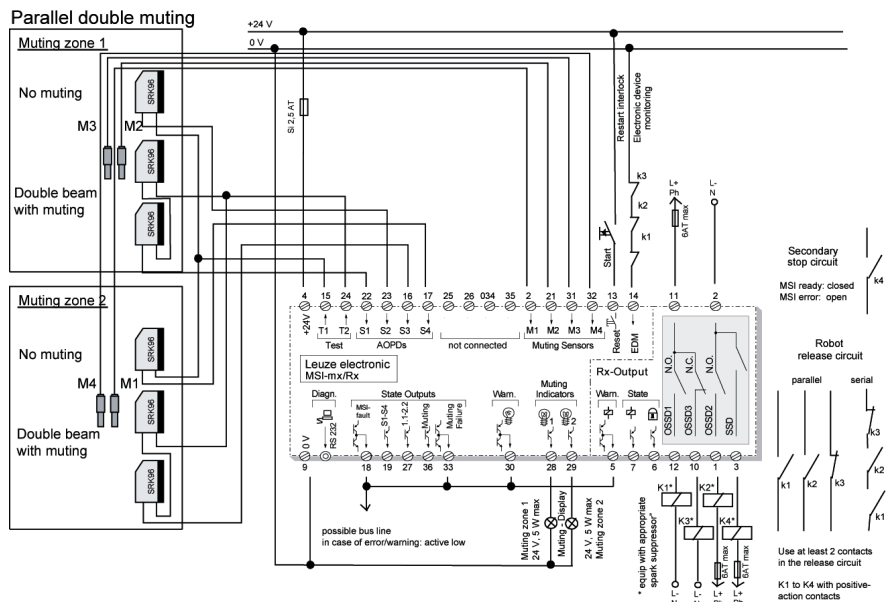

Connection example with MSI-mx/Rx.2 incorporating AOPD SRK96 type 2



Take note of chapter 3 "DIP switch settings" in the MSI-mx operating instructions. Factory setting of the I/O-mx module: MU1, 3, 4, 5 on UP; MU2 on DOWN.