

the sensor people

SRK 96

Safety Retro-reflective Light Barrier



Notes on Connecting and Operating Instructions

These connecting and operating instructions contain information on the proper use of SRK 96 Safety Retro-reflective Light Barrier in accordance with its intended purpose.



All the information contained herein, in particular the safety notes, need to be carefully observed.

Notes regarding safety and warnings are marked by this symbol .

Notes regarding important pieces of information are marked by the symbol .

This symbol  warns of possible danger through hazardous laser radiation.

This connecting and operating instructions manual must be stored carefully. It must be available for the entire operating time of the SRK 96 Retro-reflective Light Barrier.

The Leuze electronic GmbH + Co. KG is not liable for damages caused by improper use. Acquaintance with these instructions is an element of the knowledge required for proper use.

© Reprints and reproduction, in whole or in part, are permitted only with the explicit permission of

Leuze electronic GmbH + Co. KG
In der Braike 1
D-73277 Owen - Teck / Germany
Phone +49 (0) 7021 / 573-0
Fax +49 (0) 7021 / 573-199
info@leuze.de
www.leuze.com

1	General Information	5
1.1	Certifications	5
1.2	General information	5
1.3	Definition of terms	5
1.4	Selection of Optical Electronic Protective Devices	6
1.5	Determination of the protected area	6
1.6	Determination of the protective function	7
1.7	Residual risks (EN ISO 12100-1)	7
2	Safety	8
2.1	Approved purpose and foreseeable improper operation	8
	Proper use	8
	Foreseeable misuse	9
2.2	Competent personnel	9
2.3	Responsibility for safety	10
2.4	Exemption of liability	10
2.5	Special safety notices for applications with type 2 active opto-electronic protective devices	11
2.6	Safety standard	11
2.7	Areas of application	11
2.8	Working Safely	12
3	Function	14
3.1	System description	14
3.2	Description of functions SRK 96	14
3.3	Testing SRK 96	14
3.4	Function safety	15
4	Mounting and commissioning	16
4.1	Components of the safety system	16
4.2	Integration in the machine control system	16
4.3	Display element	16
4.4	Mounting of the Safety System	16
	Mounting of the protective retro-reflective photoelectric sensor SRK 96 16	
	Safety distance	19
	Multi-axle installation	20
5	Electrical Installation	21
5.1	Electrical connection	21
	Electrical connection diagrams	21
6	Technical Data	24
6.1	Safety-relevant technical data	24
6.2	General data	24
6.3	Dimensioned drawings	26

1 General Information

1.1 Certifications

The protective retro-reflective photoelectric sensor SRK 96 has been developed and produced in accordance with the applicable European standards and directives.



Note:

The corresponding declaration of conformity can be requested from the manufacturer.

The manufacturer of the product, Leuze electronic GmbH + Co. KG, in D-73277 Owen - Teck, Germany, possesses a certified quality assurance system in accordance with ISO 9001.



1.2 General information

An AOPD is part of the electrical equipment which has to be applied to those machines which contain the potential risk of bodily injury. It provides protection by causing the machine to move into a safe operating state before a person can get into a dangerous situation (ISO 13849-1).

1.3 Definition of terms

Contactless active protective device (AOPD)

A combination of parts and/or components which functions together to provide access protection or presence detection and contains at least the following:

- a sensor unit,
- control/monitoring units,
- output switching elements.

AOPD Type 2

The EN 61496 describes two types of active optical electronic protective devices (AOPD) with respect to the requirements concerning safety relevant parts of control units (ISO 13849-1).

The AOPD type 2 fulfils the requirements of category 2 acc. to ISO 13849-1. A periodic function test has to detect malfunctions in the safety function. In case of a failure, the next machine cycle may not be released. A malfunction of the AOPD type 2 between the testing can cause the loss of the safety function. In normal function, at least one output switching element of the AOPD type 2 has to move into the OFF-position if the sensor reacts or if the power supply of the AOPD is interrupted.

Start disable

An equipment which disables the automatic machine start if the power supply of the contactless active protective device is switched on or if it had been interrupted and switched on again.

Start testing

A manual or automatic test which is performed after the contactless active protective device has been switched on. It tests the complete safety-relevant control system before the normal machine operation is induced.

Restart-disable

A function which prevents an automatic restart of a machine after activation of the sensor unit during a potentially dangerous part of the machine cycle, after a change in the operating mode of the machine and a change in the actuation mode of the machine. Operating modes include:

- jog,
- single stroke,
- automatic.

Actuation modes include:

- foot control,
- two-handed control,
- single-cycle or two-cycle triggering by the sensor unit of the contactless active protection device.

1.4 Selection of Optical Electronic Protective Devices

The following strategy is to be applied (iterative process):

1. Determination of the protected area.
2. Determination of the protective function:
 - Finger or hand protection,
 - Access protection for persons,
 - Presence detection.
3. Determination of the control category.
4. Calculation of the safety distance.

1.5 Determination of the protected area

Through risk evaluation, the following has to be observed:

- the size of the protected field,
- the access points,
- the danger areas,
- bypassing possibilities.

1.6 Determination of the protective function

Finger and hand protection are necessary as the user is located close to the danger area. Access to the danger area is protected.

A danger area which is completely surrounded by permanently installed protective devices is monitored for presence of objects or access protection and presence detection are combined.

1.7 Residual risks (EN ISO 12100-1)

The wiring suggestions shown in this manual have been tested with utmost care. The relevant standards and regulations are adhered to when the shown components and appropriate wiring are used. Residual risks remain when:

- the proposed circuit concept is changed and the connected safety-relevant components or protective devices are possibly not or insufficiently included in the safety circuit.
- relevant safety regulations specified for the operation, adjustment and maintenance of the machine are not adhered to by the operator. Here, the inspection and maintenance intervals for the machine should be strictly adhered to.

2 Safety

Before using the safety sensor, a risk evaluation must be performed according to valid standards (e.g. EN ISO 14121, EN ISO 12100-1, ISO 13849-1, IEC 61508, EN 62061). The result of the risk assessment determines the required safety level of the safety sensor (see Tabelle 2.1-1). For mounting, operating and testing, document "SRK 96 Reflection Light Beam Safety Device" as well as all applicable national and international standards, regulations, rules and directives must be observed. Relevant and supplied documents must be observed, printed out and handed to the affected personnel.

Before working with the safety sensor, completely read and understand the documents applicable to your task.

In particular, the following national and international legal regulations apply for the start-up, technical inspections and work with safety sensors:

- Machinery directive 2006/42/EC
- Low voltage directive 2006/95/EC
- Electromagnetic compatibility directive 2004/108/EC
- Use of Work Equipment Directive 89/655/EEC supplemented by Directive 95/63 EC
- OSHA 1910 Subpart O
- Safety regulations
- Accident-prevention regulations and safety rules
- Ordinance on Industrial Safety and Health and Labor Protection Act
- Device Safety Act



Notice!

For safety-related information you may also contact the local authorities (e.g., industrial inspectorate, employer's liability insurance association, labor inspectorate, occupational safety and health authority).

2.1 Approved purpose and foreseeable improper operation



Warning!

A running machine can cause severe injuries!

Make certain that, during all conversions, maintenance work and inspections, the system is securely shut down and protected against being restarted again.

2.1.1 Proper use

- The safety sensor must only be used after it has been selected in accordance with the respectively applicable instructions and relevant standards, rules and regulations regarding labor protection and occupational safety, and after it has been installed on the machine, connected, commissioned, and checked by a **competent person**.
- When selecting the safety sensor it must be ensured that its safety-related capability meets or exceeds the required performance level PL_r ascertained in the risk assessment.

The following table shows the safety-related characteristic parameters of the SRK 96 Reflection Light Beam Safety Device.

Type in accordance with IEC/EN 61496	Type 2
Performance Level (PL) in accordance with ISO 13849-1 in combination with a TNT 35	PL d
Category in accordance with ISO 13849 in combination with a TNT 35	Cat. 2
Mean time to dangerous failure (MTTF _d)	198 years
Service life (T _M)	20 years

Table 2.1-1: Safety-related characteristic parameters of the SRK 96 Reflection Light Beam Safety Device

- The safety sensor protects persons at access points or at points of operation of machines and plants.
- The safety sensor only detects persons upon entry to the danger zone; it does not detect persons who are located within the danger zone. For this reason, a start/restart interlock is mandatory.
- The construction of the safety sensor must not be altered. When manipulating the safety sensor, the protective function is no longer guaranteed. Manipulating the safety sensor also voids all warranty claims against the manufacturer of the safety sensor.
- The safety sensor must be tested regularly by competent personnel.
- The safety sensor must be exchanged after a maximum of 20 years. Repairs or the exchange of parts subject to wear and tear do not extend the service life.
- Work on electrical installations must only be performed by qualified electricians.
- Adjustment and changes to the protective field for personnel protection must only be performed by a person competent to perform this work.

2.1.2 Foreseeable misuse

In principle, the safety sensor is not suitable as a protective device in case of:

- danger of objects being expelled or hot or dangerous liquids spurting from the danger zone
- applications in explosive or easily flammable atmospheres
- reachability of the points of operation by hand from the mounting location of the safety sensor
- detection of the presence of persons in danger areas

2.2 Competent personnel

Prerequisites for competent personnel:

- he has a suitable technical education
- he knows the rules and regulations for occupational safety, safety at work and safety technology and can assess the safety of the machine
- he knows the instructions for the safety sensor and the machine
- he has been instructed by the responsible person on the mounting and operation of the machine and of the safety sensor

2.3 Responsibility for safety

Manufacturer and operating company must ensure that the machine and implemented safety sensor function properly and that all affected persons are adequately informed and trained.

The type and content of all imparted information must not lead to unsafe actions by users.

The manufacturer of the machine is responsible for:

- safe machine construction
- safe implementation of the safety sensor
- imparting all relevant information to the operating company
- adhering to all regulations and directives for the safe starting-up of the machine

The company operating the machine is responsible for:

- instructing the operating personnel
- maintaining the safe operation of the machine
- adhering to all regulations and directives for occupational safety and safety at work
- regular testing by competent personnel

2.4 Exemption of liability

Leuze electronic GmbH + Co. KG is not liable in the following cases:

- safety sensor is not used as intended
- safety notices are not adhered to
- reasonably foreseeable misuse is not taken into account
- mounting and electrical connection are not properly performed
- proper function is not tested
- changes (e.g., constructional) are made to the safety sensor

2.5 Special safety notices for applications with type 2 active optoelectronic protective devices



Attention!

Type 2 protective devices are to be used if a machine-specific C standard or a risk evaluation acc. to EN ISO 14121 or ISO 13849 permits such use.



Attention!

For type 2 protective devices, the protective function is checked during periodic testing. Between the test periods, a fault may lead to a temporary loss of the protective function which will not be discovered until the next test.

The availability of the protective function is higher the shorter the test periods are. Support is available here through the organizations responsible for machine safety, such as the technical expert committees of the employer's liability insurance associations.

Optimum type 2 functional reliability is attained with the intelligent, modular MSI-s Safety Interface System, among others, or a TNT 35 Test Monitoring Unit from Leuze electronic.

2.6 Safety standard

The SRK 96 Reflection Light Beam Safety Device was developed in accordance with the currently applicable safety standards and submitted for EC Type Examination. The safety-related requirements specified by EN 61496-1/-2 type 2 are fulfilled by the SRK 96.

The SRK 96 is a Laser Reflection Light Beam Device of laser protection class 2.



Attention!

Eye protection is normally ensured by the lid-closing reflex of the eye. The laser beam path should be closed at the end of its purpose-oriented way, where this is practically and responsibly possible; furthermore, the laser should not be directed at persons (head level).

2.7 Areas of application

The SRK 96 Reflection Light Beam Safety Device may be used in combination with a test monitoring unit (TNT 35/TMC 66) as a disconnecting protective device for safeguarding danger areas at power-driven machinery.

It is approved for the following areas of application (excerpt):

- Edge-, frame-, star- and carcass presses in wood processing
- Print and paper processing machines
- Power-operated windows, doors and gates
- Storage equipment and devices
- Textile machinery
- Food processing equipment
- Packaging machinery
- Meat processing equipment
- Machinery in the chemicals, rubber and plastics industry

2.8 Working Safely



The SRK 96 Reflection Light Beam Safety Device operates with a class 2 red-light laser acc. to EN 60825-1 and also satisfies 21 CFR 1040.10 with the exception of the deviations acc. to Laser Notice No. 50 from July 2001. Looking into the beam path for a longer period of time can damage the retina in the eye!

Never look directly into the beam path!

Never point the laser beam of the SRK 96 at persons!

When mounting and aligning the SRK 96, watch for reflections of the laser beam off of reflective surfaces!

If control and adjustment equipment other than that specified in this technical description are used, if different processes are performed, or if the SRK 96 Reflection Light Beam Safety Device is used improperly, dangerous radiation exposure may result!

The use of optical instruments or equipment together with the device increases the risk of damage to the eyes!

Adhere to the applicable legal and local regulations regarding protection from laser beams acc. to EN 60825-1 in its latest version.

The SRK 96 uses a low-power laser diode in the visible red-light range with an emitted wave length of approx. 670 nm. The output power of the laser beam at the reading window is at most 2.2 mW acc. to EN 60825-1.

The optical window is the only outlet opening through which the laser radiation can exit the device. The housing of the SRK 96 Reflection Light Beam Safety Device is sealed and contains no parts that can be adjusted or serviced by the user. Interventions and changes to the device are not permissible!



Notice:

The supplied stick-on labels (notice signs and laser outlet symbol) must be affixed to the device! If the signs are covered due to the installation situation of the SRK 96, instead affix the signs near the SRK 96 so that one cannot look into the laser beam while reading the notices!



LASERSTRAHLUNG
NICHT IN DEN STRAHL BLICKEN
Max. Leistung: 2,2mW
Impulsdauer: 10µs
Wellenlänge: 670nm
LASER KLASSE 2
DIN EN60825-1:2003-10

LASER LIGHT
DO NOT STARE INTO BEAM
Maximum Output: 2.2mW
Pulse duration: 10µs
Wavelength: 670nm
CLASS 2 LASER PRODUCT
EN60825-1:2003-10

RAYONNEMENT
NE PAS REGARDER DANS LE FASCEAU
Puissance max.: 2,2mW
Durée d'impulse: 10µs
Longueur d'onde émise: 670nm
APPAREIL A LASER DE CLASSE 2
EN60825-1:2003-10

LASER LIGHT
DO NOT STARE INTO BEAM
Maximum Output: 2.2mW
Pulse duration: 10µs
Wavelength: 670nm
CLASS 2 LASER PRODUCT
IEC 60825-1:1993+A2:2001
Complies with 21 CFR 1040.10

AVOID EXPOSURE - LASER LIGHT
IS EMITTED FROM THIS APERTURE

Figure 2.8-1: Affixing the stick-on labels with warning notices

When using the SRK96 in the USA, please use the notice sign shown below (complies with 21 CFR 1040.10).

3 Function

3.1 System description

The contactless active protective device (AOPD) of type 2 consists of the SRK 96 protective retro-reflective photoelectric sensor and a special reflector PTKS 20x40, PTKS 50x50 (preferred type) or PTKS 100x100.



Warning!

The system does not function with commercially available standard reflectors.

For the use acc. to EN 61496-1 type 2, the system must be connected to an appropriate test monitoring unit (for example TNT 35/TMC 66).

3.2 Description of functions SRK 96

The SRK 96 protective retro-reflective photoelectric sensor is a single-lens, laser photoelectric sensor.

The light beams transmitted by the transmitter are incident on a reflector unit which is mounted stationary at the opposing side of the area being monitored. The light beams reflected from there are correspondingly evaluated by the receiver unit.

The unique feature of the reflector unit is that a polarisation filter is positioned in front of a triple reflector. This ensures that only linearly polarised light can be reflected.

A comparison of the constituent linearly polarised light and unpolarised light components is performed by a corresponding evaluation system in the receiver unit.

If the beam path is interrupted by a diffusely reflecting object or a standard reflector (unpolarised), it is possible to clearly identify a change in the polarisation ratio.

3.3 Testing SRK 96

The test function is initiated by dropping the input voltage at the activation input below 2V. The switching output of the SRK 96 is deactivated approx. 8.5 ms after the test is initiated and reactivated after a maximum subsequent 2.7 ms.

This state is internally evaluated upon connection of a TNT 35/TMC 66 test monitoring unit. The output safety circuits of the test monitoring unit are not affected by the test function.

3.4 Function safety

Device malfunctions are detected through monitoring and by internal/external testing and put the system into a safe state.

There are various options available for the external testing and monitoring of the SRK 96. A suitable test and monitoring circuit can be assembled using conventional controls (contactor technology) or programable logic controls (PLC). Here, ensure that the test/monitoring circuit is assembled in accordance with the specifications of the corresponding safety class. Only then does the contactless active protective device meet type 2 acc. to EN 61496-1.

For this reason, it is recommended in all cases to use a test monitoring unit of type TNT 35 or TMC 66 (with integrated muting controller). These have been confirmed by an EU type examination acc. to type 2 (EN 61496-1).

4 Mounting and commissioning

4.1 Components of the safety system

The complete safety system consists of one or more SRK 96 protective retro-reflective photoelectric sensors with corresponding number of reflectors of type PTKS 20x40, PTKS 50x50 (preferred type) or PTKS 100x100 and the corresponding test-monitoring circuit / device (for example TNT 35 or TMC 66).

4.2 Integration in the machine control system

The electrical integration into the control has to be performed acc. to the set safety category acc. to ISO 13849-1. The voltage free safety relay outputs of a test monitoring unit (e.g. TNT 35) can be directly used for shutdown of the dangerous movement.

The advantage of using the TNT 35 and TMC 66 test/monitoring unit is that an EU type examination is available for both parts of the contactless active protective device (SRK 96 and TNT 35 or TMC 66).

This means that, in this combination, validation acc. to EN 61496-1 is no longer necessary as this has already been performed by the manufacturer and the testing agency.

Depending on the type of integration, the use of a contactor control or a start- and restartdisable may be necessary. These functions are already integrated in the TNT 35 and TMC 66 devices.

4.3 Display element

The protective retro-reflective photoelectric sensor SRK 96 features two integrated LEDs.

The LEDs indicate the following operating states:

- LED green Ready (supply voltage is present),
- LED yellow Light path free (output activated),
- LED yellow flashing Light path free, no performance reserve.

4.4 Mounting of the Safety System

4.4.1 Mounting of the protective retro-reflective photoelectric sensor SRK 96

When mounting the SRK 96, take particular care that the PTKS 20x40, PTKS 50x50 (preferred type) or PTKS 100x100 reflectors, used specially for this configuration, are mounted in the correct position. The reflector must be mounted in such a way that the reflector mounting surface (back wall) is perpendicular to the optical axis.

To ensure high availability of the system, when installing the SRK 96 make certain that there are no strongly radiating light sources in the beam path. If necessary, swap positions of the SRK 96 and the PTKS... reflector or mount them in such a way that the light source is not directly in the beam path. When mounting, ensure that there are no strongly reflective surfaces or standard reflectors in the immediate vicinity of the PTKS... reflector.



Bild 4.4-1: Arrangement of the reflector



Warning!

If the reflector is mounted in the wrong position, the system will not function.

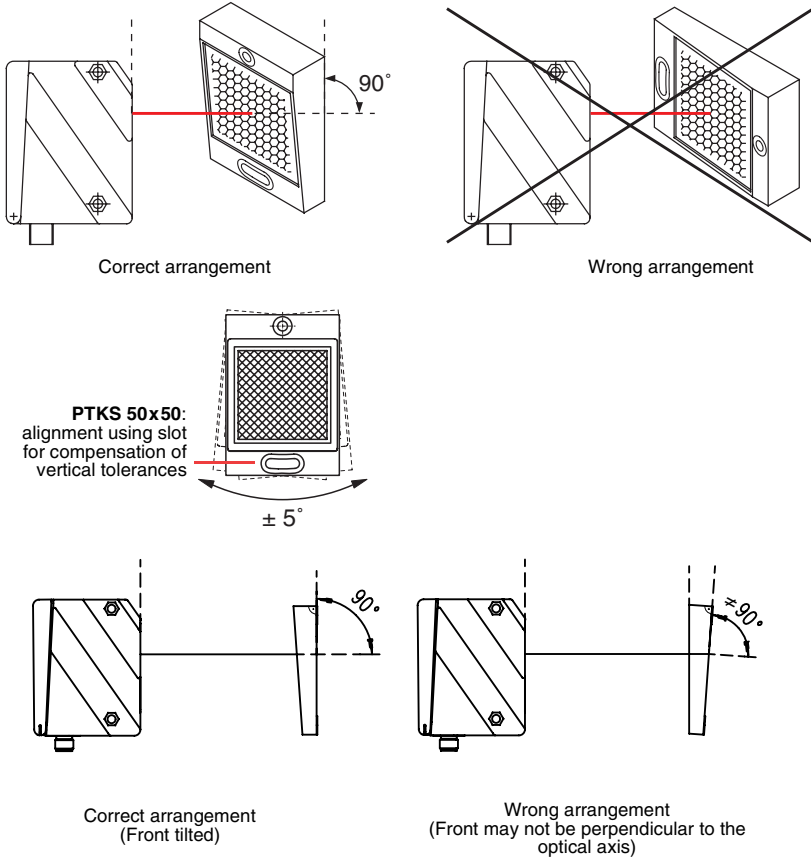
Install the SRK 96 in such a way that the front cover is not subject to any mechanical tension. It is recommended that the photoelectric sensor be screwed down only at the fastening holes provided for this purpose. Use the mounting sleeves supplied (see fig 4.4-2) when mounting on or between plane-parallel surfaces.



Bild 4.4-2: Mounting to or between plane-parallel surfaces



Warning!

After aligning the SRK 96 to the PTKS... reflector (yellow LED on the SRK 96 illuminates), check the horizontal pitch of the light axis. The reflector mounting surface should be perpendicular to the light axis (siehe Abb. 4.4-1).

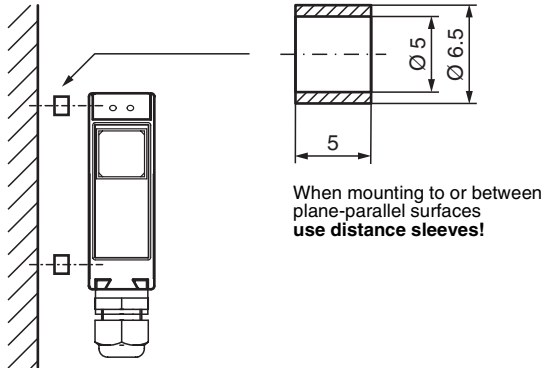
It is absolutely mandatory that the valid guidelines and standards are observed when mounting protective photoelectric sensors.



Note:

the mounting instructions in this chapter have to be heeded for fault-free functioning of the whole safety system.

4.4.2 Safety distance

A certain time delay applies between the interruption of the light beam of the protective photoelectric sensors and the stand-still of the machine. The photoelectric sensors have to be installed in such a way that the dangerous area can not be reached within this time delay. The minimum distance for safeguarding the danger area is 850 mm.



Bild 4.4-3: Safety distance from the danger area

Calculation of the safety distance

The safety distance **S** between photoelectric sensor and danger area is calculated acc. to EN 999 using the following formula:

$$S = K * T + C$$

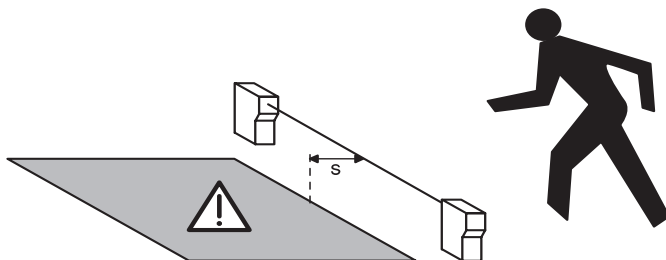
- S = Safety distance between photoelectric sensor and danger area
- K = Grip and approach speed
- T = Time delay between interruption of the light beam and stand-still of the machine
- C = Safety constant
 - 1200 mm with uniaxial installation,
 - 850 mm with multi-axle installation

Example for the calculation of the safety distance:

This example assumes a machine with a system response time of 500 ms and a two-axle safeguard by the SRK 96 system. The response time of the SRK 96 and TNT 35 test monitoring unit is 20 ms.

Application of the formula: $S = K * T + C$:

Where:

S = the minimum distance of the SRK 96 systems from the danger area

K = approach speed 1600 mm/s (EN 999)

T = sum of the system response time of the machine and response time of the AOPD
(500 ms + 20 ms = 520 ms)

C = 850 mm with multi-axle installation

this results in:

$S = (1600 \text{ mm/s} * (500 \text{ ms} + 20 \text{ ms})) + 850 \text{ mm}$

S = 1682 mm

4.4.3 Multi-axle installation

For the safeguarding of danger areas, the protection heights and the number of photoelectric sensors are determined in EN 999 or through a risk analysis acc. to ISO 13849-1.

Number of photoelectric sensors	Mounting height above access level in mm			
1	750			
2	400	900		
3	300	700	1100	
4	300	600	900	1200

Tabelle 4.4-1: Protection heights and number of photoelectric sensors

Depending on the number of photoelectric sensor pairs, the single systems have to be mounted at different heights acc. to EN 999. The number of needed systems results from the corresponding type C standard or risk evaluation.

5 Electrical Installation

The electrical installation is only to be performed by authorised and specialised personnel. During installation, ensure that the supply and signal lines are laid separate from mains lines. Inside the switching cabinet, suitable spark extinction has to be provided if using contactors. In connection with driving motors and breaks, the corresponding manuals have to be observed.

5.1 Electrical connection

The electrical connection of the SRK 96 is to be performed acc. to the connection figures shown below.

The activation input (terminal 4/with plug connection PIN 2) is active upon application of DC voltage $\geq 8V$. The transmitter now functions and emits visible red light.

If the activation input drops below a DC voltage of $\leq 2V$, the internal test of the SRK 96 is triggered.

In normal operation, the activation input is controlled by the test-monitoring circuit, for example TNT 35.

5.1.1 Electrical connection diagrams



Bild 5.1-1: Electrical connection diagrams

Connection diagram SRK 96 with TNT 35

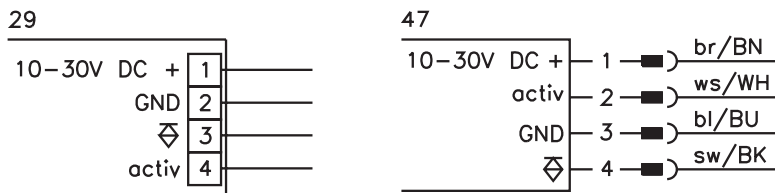

Bild 5.1-2: Connection SRK 96 with TNT 35

Connection diagram SRK 96 with TMC 66

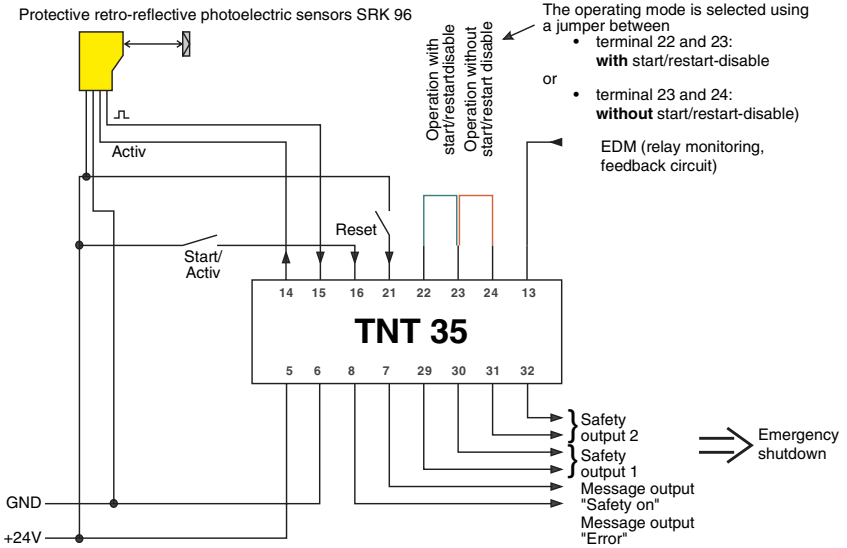

Bild 5.1-3: Connection SRK 96 with TMC 66

6 Technical Data

6.1 Safety-relevant technical data

Type in accordance with IEC/EN 61496	Type 2
Performance Level (PL) in accordance with ISO 13849-1 in combination with a TNT 35	PL d
Category in accordance with ISO 13849 in combination with a TNT 35	Cat. 2
Mean time to dangerous failure (MTTF _d)	198 years
Service life (T _M)	20 years

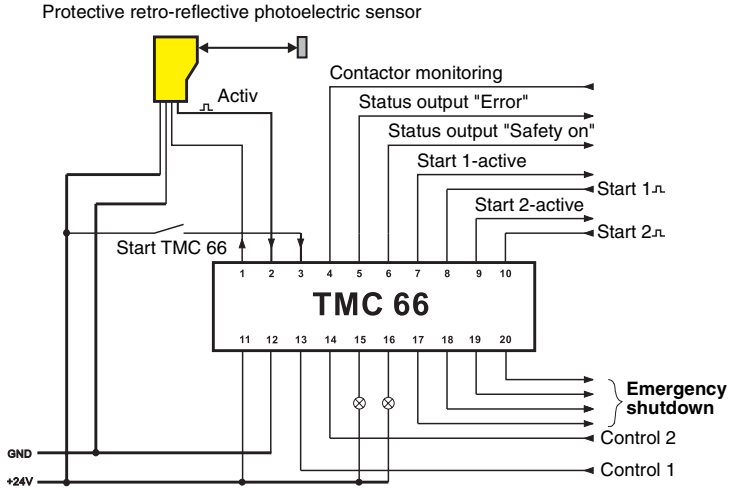
6.2 General data

Optical data	
Typ. Operating range limit ¹⁾	0,5 ... 7 m
Operating range ²⁾	0,5 ... 6 m
with reflector	PTKS 50x50 (preferred type)
Light source	red light laser diode
Wavelength	670 nm
Laser class	2 acc. to EN 60825-1: 1993 + A1:2002 + A2:2001
Timing	
Switching frequency	100 Hz
Response time	6 ms
Delay before start	≤ 200 ms
Electrical data	
Operating voltage U _B	10 ... 30VDC (incl. residual ripple)
Residual ripple	≤ 15% of U _B
Bias current	≤ 40 mA
Switching output	PNP transistor
Function	light switching
Signal voltage high/low	≥ (U _B - 2V) / ≤ 2V

- 1) Typ. operating range limit: max. attainable range without performance reserve
 2) Operating range: recommended range with performance reserve
 3) 1=transient protection, 2=polarity reversal protection, 3=short circuit protection for all outputs,
 4=interference blanking
 4) Rating voltage 250VAC

Tabelle 6.2-1: Specifications

Output current	max. 100 mA
Indicators	
LED green	ready
LED yellow	light path free
LED yellow flashing	light path free, no performance reserve
Mechanical data	
Housing	diecast zinc
Colour	yellow
Optics cover	glass
Weight	380 g
Connection type	terminals or M12 connectors
Environmental data	
Ambient temp. (operation/storage)	-10°C ... +50°C/-30°C ... +60°C
Protective circuit ³	1, 2, 3, 4
VDE safety class ⁴	II, all-insulated
Air humidity	humidity class G acc. to IEC 68 part 2-3
Storage temperature	-30°C - +60°C
Protection class	IP 67
Impact resistance	semi-sine 30 gn, 11 ms (VDE 0660 T 208)
Vibration resistance	10 ... 55Hz, max. 7,5gn (VDE 0660 T 208)
EMB/EMV	acc. to EN 61496-1
Options	
Activation input active	≥ 8V/≤ 2V
Input resistance	10kΩ ± 10%
Testing time	12 ms + response time test monitoring unit

- 1) Typ. operating range limit: max. attainable range without performance reserve
2) Operating range: recommended range with performance reserve
3) 1=transient protection, 2=polarity reversal protection, 3=short circuit protection for all outputs, 4=interference blanking
4) Rating voltage 250VAC

Tabelle 6.2-1: Specifications

6.3 Dimensioned drawings

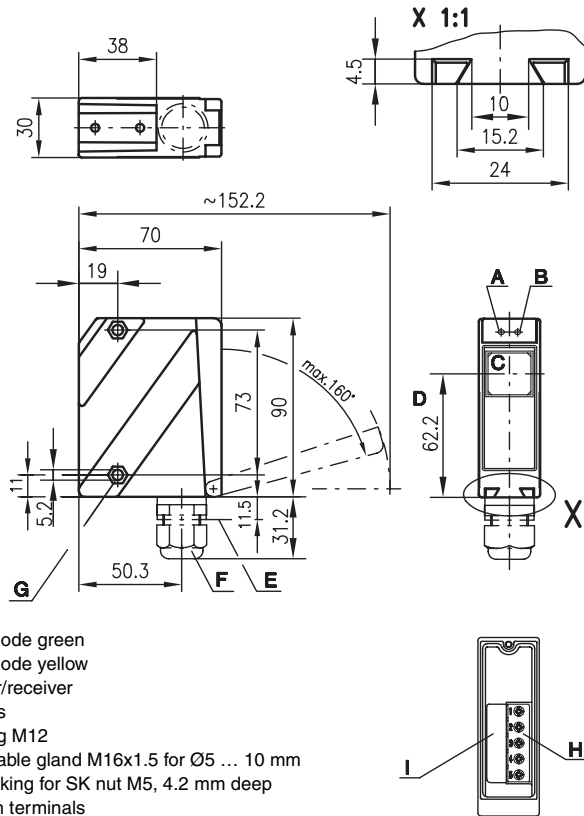

- A Indicator diode green
- B Indicator diode yellow
- C Transmitter/receiver
- D Optical axis
- E Device plug M12
- F Screwed cable gland M16x1.5 for Ø5 ... 10 mm
- G Countersinking for SK nut M5, 4.2 mm deep
- H Connection terminals
- I Cable entry

Bild 6.3-1: Dimensioned drawing SRK 96



Bild 6.3-2: Dimensioned drawings for PTKS... reflectors

EG-KONFORMITÄTS- ERKLÄRUNG (AUSZUG)	EC DECLARATION OF CONFORMITY (EXTRACT)	DECLARATION CE DE CONFORMITE (EXTRAIT)
Der Hersteller	The Manufacturer	Le constructeur
erklärt, dass die nachfolgend aufgeführten Produkte den einschlägigen Anforderungen der genannten EG-Richtlinien und Normen entsprechen.	declares that the following listed products fulfil the relevant provi- sions of the mentioned EC Direc- tives and standards.	déclare que les produits identifiés suivants sont conformes aux directives CE et normes men- tionnées.
Produktbeschreibung:	Description of product:	Description de produit:
Einstrahl-Sicherheits-Reflexions- Lichtschanke, Berührungslos wirkende Schutzeinrichtung, Sicherheitsbauteil nach 2006/42/EG Anhang IV SRK 96	Reto-reflective light barrier, Active opto-electronic protective device, safety component in acc. with 2006/42/EC annex IV SRK 96	Barrage photoélectrique reflex, Équipement de protection électro- sensible, Élément de sécurité selon 2006/42/CE annexe IV SRK 96
Angewandte EG-Richtlinie(n):	Applied EC Directive(s):	Directive(s) CE appliquées:
2006/42/EG 2004/108/EG	2006/42/EC 2004/108/EC	2006/42/CE 2004/108/CE
Angewandte Normen:	Applied standards:	Normes appliquées:
EN 61496-1:2004; CLS/TC 61496-2:2006		
Bevollmächtigter für die Zusammenstellung der technischen Unterlagen:	Authorized person to compile the technical file:	Personne autorisée à constituer le dossier technique:
Robert Sammer; Leuze electronic GmbH + Co. KG, business unit safety systems Liebigstr. 4; 82256 Fuerstenfeldbruck; Germany		

Leuze electronic GmbH + Co. KG
In der Braike 1
D-73277 Owen
Telefon +49 (0) 7021 573-0
Telefax +49 (0) 7021 573-199
info@leuze.de
www.leuze.com
LEO-ZQM-149-01-FO

Leuze electronic GmbH + Co. KG, Sitz Owen, Registergericht Stuttgart, HRA 230712
Persönlich haftende GesellschafterIn Leuze electronic, Geschäftsführungs-GmbH,
Sitz Owen, Registergericht Stuttgart, HRB 230550
Geschäftsführer: Dr. Hans-Joachim Gröbel (Vorstandsvize), Karsten Just
USt-IdNr. DE 145912521 | Zollnummer 2554232
Es gelten ausschließlich unsere aktuellen Verkaufs- und Lieferbedingungen
Only our current Terms and Conditions of Sale and Delivery shall apply

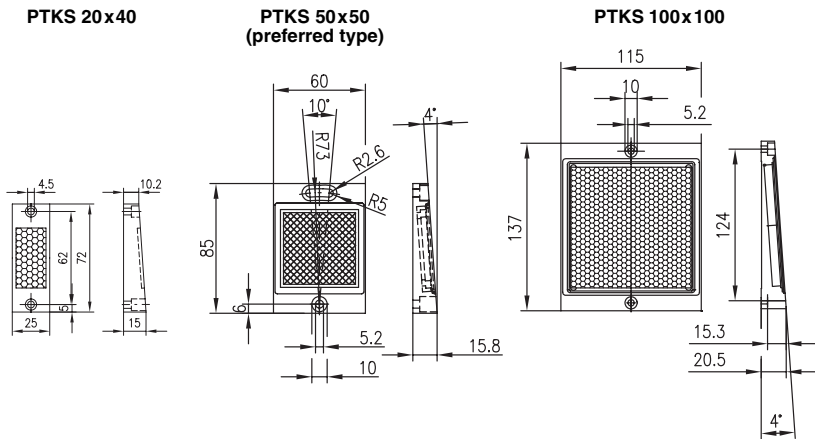
Nr. 609428-2010/08

You can also download the complete EC Declaration of Conformity from the Internet under:
<http://www.leuze.com/sls>